

Supplies and accessories

- 2466 Sealable deck lead-through
- 2448 Exhaust tube ø 28/45 mm inox
- 30012 Magnetic valve 12V/0,5 A
- 30011 Tank fitting / diesel
- 367215 Tank feed through, diesel
- 1012 Fastening equipment for the upper part of the stove
- 270 Heat blower lid
- 2024 Fuel tanki, 5 l
- 2027 Fuel tank, 10 l

Package contents

800 D	
1 pcs	Stove 800 D
1 pcs	Fuel hose (4m)
1 pcs	Power cable with connector (4m)
1 pcs	Accessory bag 17748
4 pcs	Fastening screw 4,25 x 25
1 pcs	Hose clamp 32 - 50 mm
1 pcs	1 pc decorative frame and 4 pcs M3 X 8
1 pcs	Control panel package 361070
1 pcs	Control panel
1 pcs	Extension collar
1 pcs	Control panel cable, 6 m
4 pcs	Control panel fastening screws 3,5 x 20 mm (black) TX 10
4 pcs	Control panel fastening screws 3,5 x 40 mm (black) TX 10
1 pcs	Fuel filter package 603721
1 pcs	Fuel filter
4 pcs	Hose clamp 8 mm
2 pcs	Hose clamp 10 mm
2 pcs	Rubber hose ø 5 mm
1 pcs	Rubber hose ø 6 mm
1 pcs	Installation, operation and maintenance instructions

Stove operation

The **800 D** is a safe diesel stove with no open flame. The stove is equipped with a single burner which burns either diesel oil or light furnace oil. The cooker takes the air needed for flame combustion from outside and blows exhaust gas out with the help of combustion air fan.

The fuel pump in the stove dispenses fuel, and the electronics control the combustion air and the amount of fuel automatically to keep the flame of the burner clean.

When the stove is switched on, the glow plug in the burner ignites the fuel that has been pumped into the burner. The glow time is fixed: it begins and ends automatically.

Temperature sensor inside the cooker detects the flame heat and switches on the red LED signal light on the control panel as the sign of successful ignition.

The heat which is released as the fuel burns is transferred into the ceramic stove top. The power of the stove can be adjusted steplessly.

When the stove is switched off, it cools down automatically. The cooling function ventilates the burner and discharges the flue gases generated during the switch-off outside the boat.

The stove lends itself extremely well to cooking and warming up all kinds of foods.

Technical information

	800 D
Fuel	Diesel oil, light furnace oil
Operating voltage	12 V DC
Consumption	0,10 - 0,15 l/h
Heating power	900 - 1400 W
Power consumption	Max 0,4 A (stove) Max 0,6 (heat blower lid)
Measurements	331 x 271 x 227 mm
Weight	Appr. 7 kg
Max. permissible length of the flue gas pipe	2 m
Max. permissible length of the fuel hose	8 m
Minimum size of the replacement air opening	150 cm ² 24 square inches
Suitable flue gas lead-throughs	2460, 5400, 2467

Things to note when selecting the installation location

When installing the device, bear in mind that the device must be detached for maintenance. Therefore, it is advisable to make the connections easy to open and disconnect.

The stove should be installed level. The inclination must not exceed 5°. While the device might not break if it is temporarily tilted to a steep angle (even for some hours), the burner will not yield optimal performance if it is constantly inclined. Also consider where you will place the control panel, as the length of the control panel's cable may pose some limitations.

Avoid installing the control panel in the immediate vicinity of a water outlet.

If possible, install the control panel on a vertical surface.

Moreover, the stove should not be installed on top of a refrigerator. The stove will heat its surroundings and thus decrease the power of the refrigerator.

We recommend that the device be installed by an authorised Wallas service shop.

Things to note when installing pipes, hoses and cables

Power cables and fuel hoses must be protected in locations where they are susceptible to mechanical damage due to sharp edges or heat.

The necessary installation tools



5 mm



ø 2 mm
ø 5 / ø 6 mm



6,5 mm TX 10



7 / 8 mm
10 mm
12 mm



ø 35 / ø 50 mm

Stove installation

Saw a cut-out (see picture) for the stove and the control panel in your chosen location.

The length of the control panel cable is 3 m.

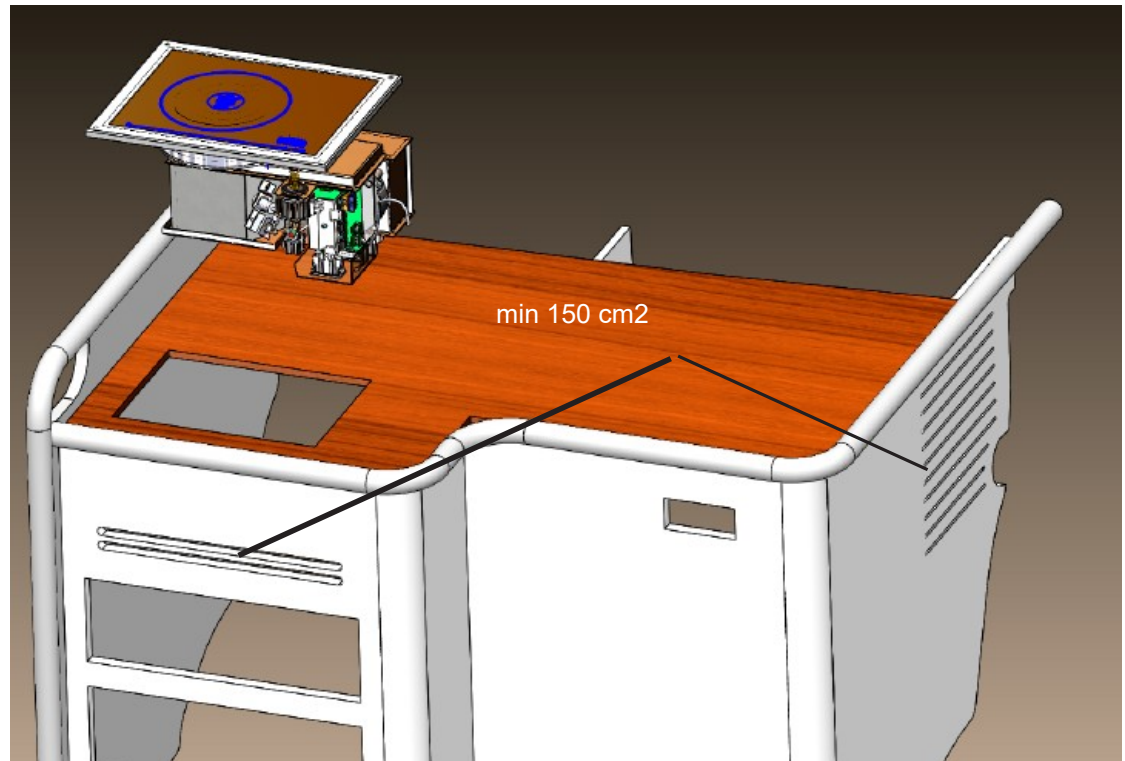

You can also fabricate a detachable panel to go in front of the stove. This will facilitate installation and maintenance.

Ensure that there is sufficient space under the stove for cables and hoses.

The control panel should be installed on a vertical surface.

Dimensions of the equipment

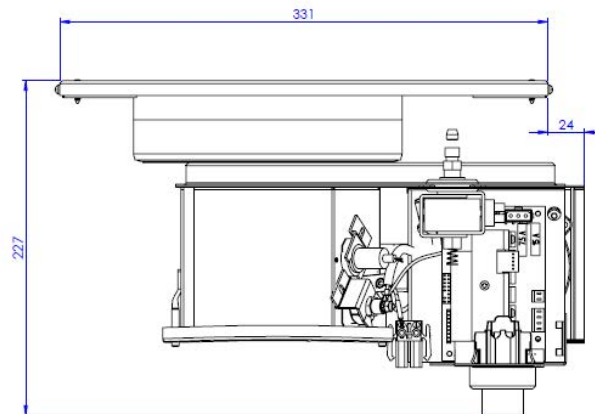

Dimensions of the cooktop

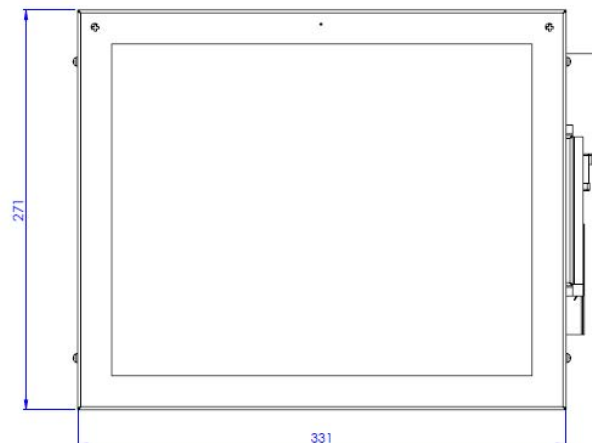

Fastening the device



The mounting surface must withstand at least 100 °C heat.

Size of mounting aperture.

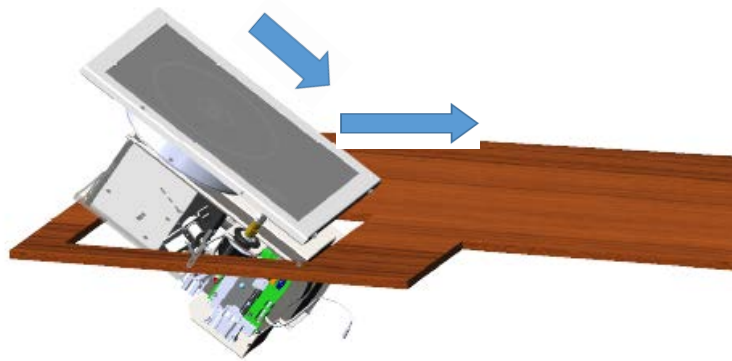
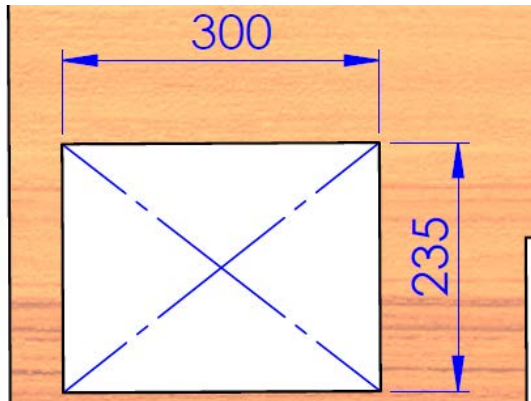

Take into account total width of the equipment (see previous page), so that you would not make the aperture too close for example to the wall.

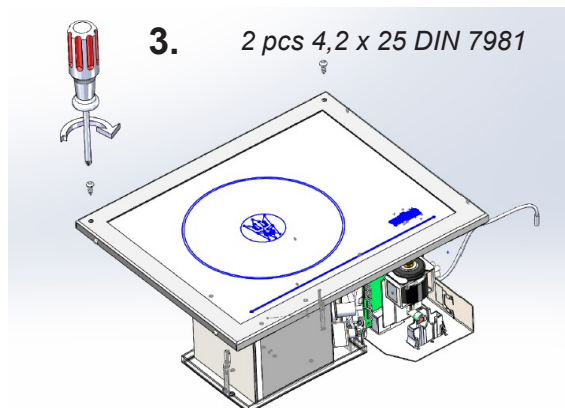
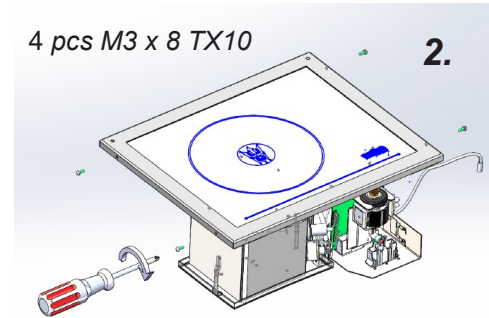
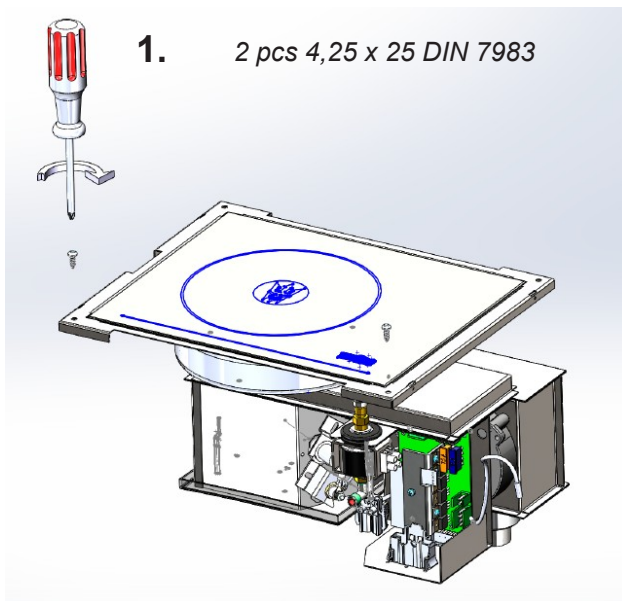

Connections of the device

Things to note about the connections

In installation, to make the mounting and demounting for service easier, it is recommended to leave some extra length of loose cables and fuel line by creating a coil. If the installation location is cramped, it is recommended to connect the cables and the fuel line to the device before mounting the unit to bracket. This will help the installation of device.

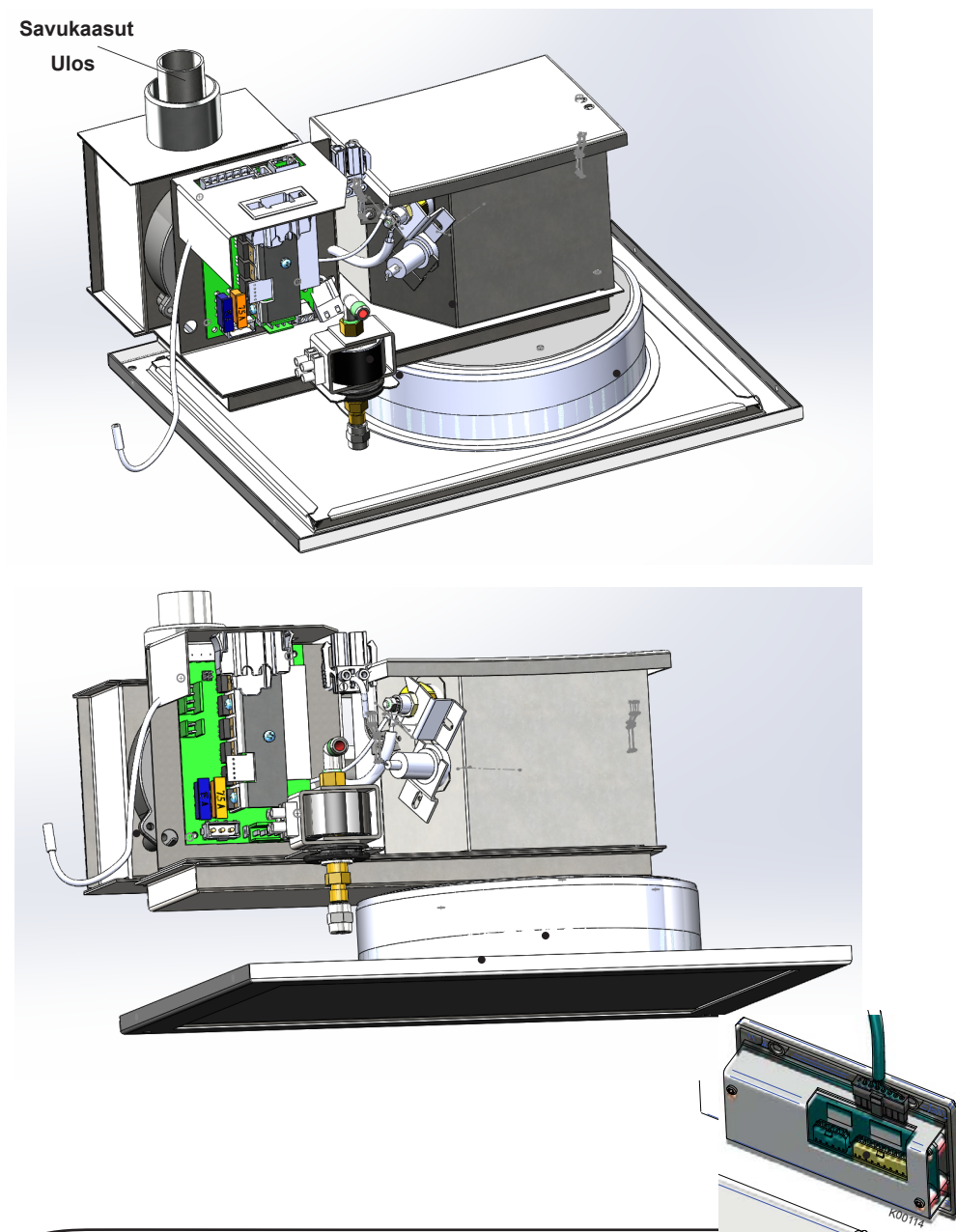

In a metal-hulled boat, you must ensure that the device, the flue gas lead-through, the fuel connection, the control panel, and all other parts are insulated from the boat's hull. This must be done to:

- prevent electrochemical corrosion
- prevent voltage from being transmitted from the hull to the device or vice versa during electrical faults.
- accessory code 2461

Control panel installation

Cut a suitable installation hole for the control panel in the selected location. Try to install the panel in a vertical surface in a location that will remain dry.



The thermostat sensor is in the panel face, so select the location with thermostatic operation/regulation in mind. Do not install close to heat source or close to a window or door. Avoid locations that might be contacted by direct sunlight. The length of the control panel cable is 3 m.

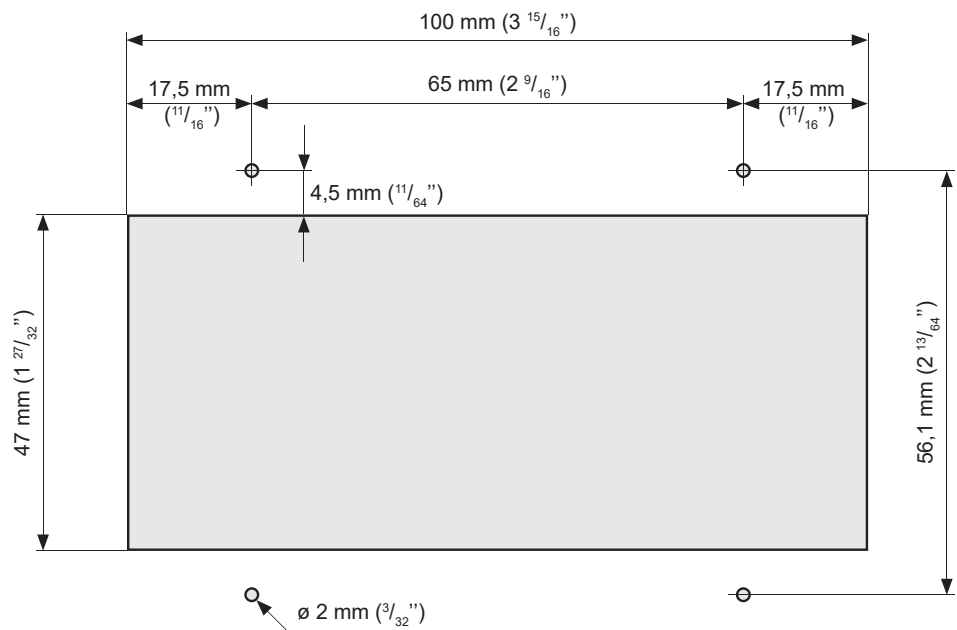

Measurements of the control panel installation cut-out. If necessary, predrill holes for the \varnothing 2 mm (3/32") screws.



You can utilize the sample of the box when drawing the lines of the installation hole.

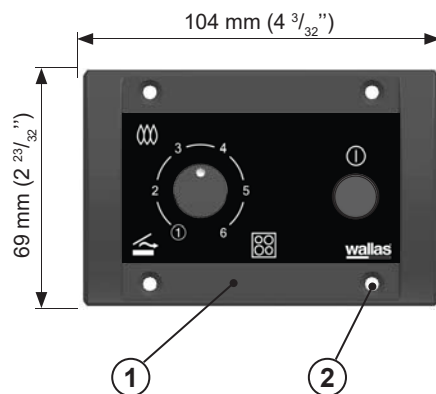

Connect the control panel cable from the device to the control panel (1). Use the fastening screws to install the control panel to the installation cut-out (2).

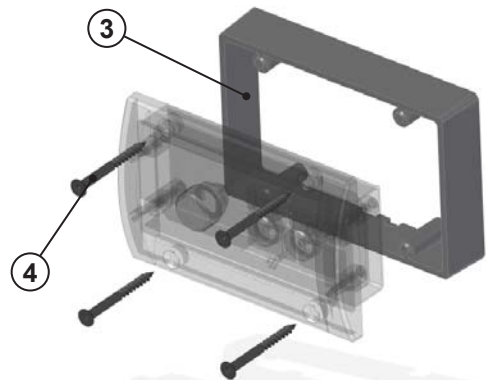

An extension collar (3) is used when control panel is surface mounted. The box of the panel includes 4 pcs screws 3,5 x 40mm (black) TX10 (4).

Electrical connections

Things to note about the connections

The device uses 12 V (nominal) direct current voltage. To minimize current losses, make the power cable as short as possible and avoid joining. The cross-sectional area of the cable is dependent on the length of the power cord. The cross-sectional area of the cable must be consistent all the way from the stove to the battery. The maximum length of the power cord is 10 m.

The cross-sectional area of the cable

Total length of the power cord (m)	Cross-sectional area of the cable in square mm (US Gauge)
0 - 4	4 (11 or 10 AWG)
4 - 6	6 (9 or 8 AWG)
6 - 10	10 (7 or 6 AWG)

If a thicker cable is required, make a separate joint in the power cord. See picture on the next page.

Main switch

A main switch must be installed on the device's "positive (Red)" cord. Always cut the power at the main switch (after cooling has completed), if the device is going to be left unused for a long period of time.



Never use the main switch to cut the power before the cooling phase, which starts after device is turned off, is completed.



Always use original Wallas accessories and parts with Wallas equipment.

Electrical connections of the device

12 V direct current system

Connect the red wire of the power cord to the plus terminal of the battery and the black or blue wire to the minus terminal. A 15 A main fuse must be installed near the battery on the red plus wire of the power cord. See picture.

24 V direct current system

If the device is to receive power from a 24 V system, always connect a charging voltage reducer and a 12 V battery before connecting the device. Without the battery the voltage reducer will not be enough on its own as it cannot generate the large amount of current the glow plug requires. After the 12 V battery, the connection is the same as in a 12 V system.



The device has to be connected to the house battery of the boat.

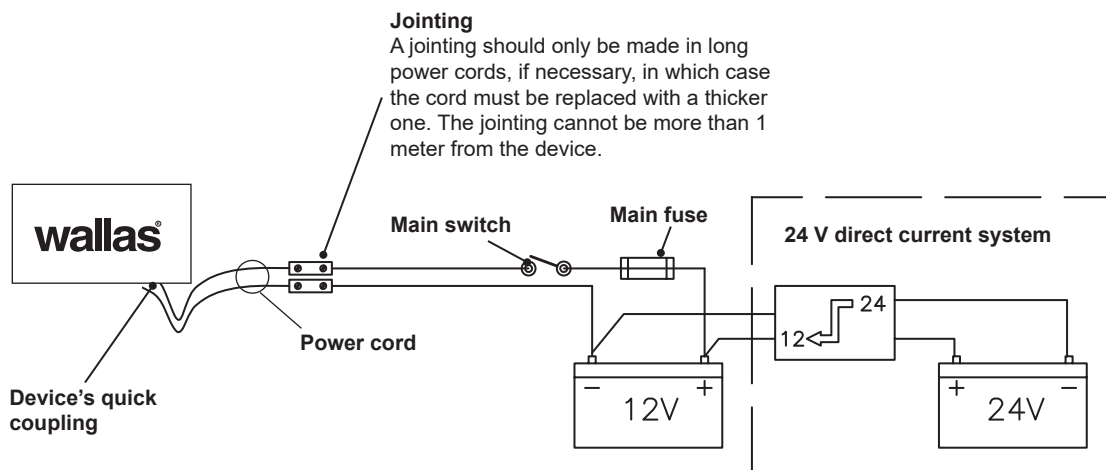

Joining
A joining should only be made in long power cords, if necessary, in which case the cord must be replaced with a thicker one. The joining cannot be more than 1 meter from the device.

Checking the connection

The device consumes most power when it is started up (glowing). At this point voltage losses are also at their highest. During the glowing phase, the voltage must be at least 11,5 V measured at the quick coupling. See picture. If the voltage is lower than this, the device may not start.

Fuel connections

Things to note about the connections

The standard length of the fuel hose is 4 m (max 8 m) 13' (max 26'). Cut the fuel hose to a length suitable for installation.

The lift height of the pump should be less than 2 m (7'); preferably 0.5 – 1 m.

The fuel pipe must always have a Wallas filter. The fuel filter can be installed either near the device, near the tank, or in another location where it can be easily checked and replaced, when necessary.

Diesel engine fuel filters and/or separators are not approved for use. All soft connections should be made with rubber or silicone hose which is resistant to diesel.

Country-specific requirements

The standard fuel hose is plastic. Please observe country-specific requirements with regard to the material of the fuel hose/pipe and the fuel filter. The inner diameter of a new replacement hose should be equal to the inner diameter of the plastic hose. Copper pipe and metal filters are available as accessories.

Fuel feed

If the lift height exceeds 2 m, the fuel feed must be checked and, if necessary, adjusted. The fuel feed must also always be checked, if parts of the fuel system, such as the pump or the electronics card, have been replaced.

Fuel system adjustments are device specific. These adjustments should only be carried out by an authorized service shop.

Connection to a fixed tank

The device must have a separate connection as well as a fuel filter outside the tank.

Connection to a separate tank

Cap run-throughs and sintered filters are used on plastic tanks.

The fuel tank should be mounted securely.

The fuel tank should be placed close to the keel line.

Wallas fuel tanks

Volume	length x height x width	Order code	
5 l	200 x 300 x 130 mm	2024	(accessory)
10 l	380 x 195 x 210 mm	2027	(accessory)
30 l	590 x 200 x 300 mm	4030	(accessory)
130 l	800 x 400 x 600 mm	4130	(accessory)



The fuel connections must be tightened firmly so that the air cannot leak into the hose. Always check the cleanliness of the connection surfaces before tightening. Air leaks in the fuel system will cause the device to malfunction.

Installation instructions for Tank connection 30011 (accessory)

- You will need to make a \varnothing 25 mm (1") hole in the upper surface of the fuel tank. Choose the location of the hole so that when the boat tilts the end of the intake pipe will stay in the fuel even if the tank is not full. If the end of the intake pipe does not reach the fuel, the device will quickly choke on the air in the fuel system.
- Cut the fuel intake pipe (\varnothing 6 mm) to the appropriate length. The end of the pipe must not touch the bottom of the tank in order to keep water and sediment from the system. It is recommended to cut the pipe short enough to leave the engine intake pipe at a lower level. This way the device cannot empty the tank.
- Install the pipe straight end first and angle the two "ears" below the threaded barrel inside the hole and then align the threaded barrel vertically so the ears are hooked on the underside of the tank top. Carefully slip the rubber washer over the bent pipe end and over the threaded barrel, followed by the metal washer and the nut. Thread the nut to the threaded barrel and tighten, sealing the fitting to the top surface of the tank.

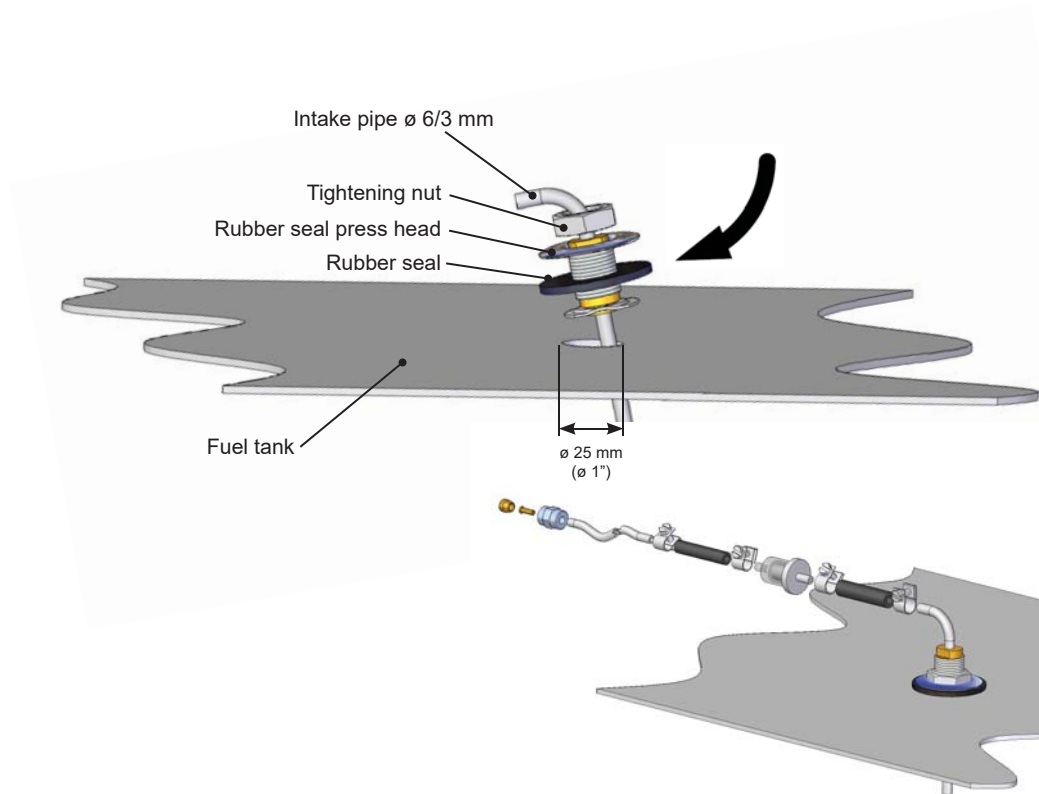

If the device uses the main tank of the boat, note that the device cannot take the fuel from the same fuel output line as the engine of the boat.

Installation instructions for Tank connection 367215 (accessory)

If the fuel will be taken from a separate tank, you must install a tank connection 367215.

- Tighten the barrel nut tightly to the fuel pump connector. Keep the parts and the hose clean and ensure that the connection is tight, because an air leak in the connector will stop the device from functioning.
- Install the tank connection in the tank.

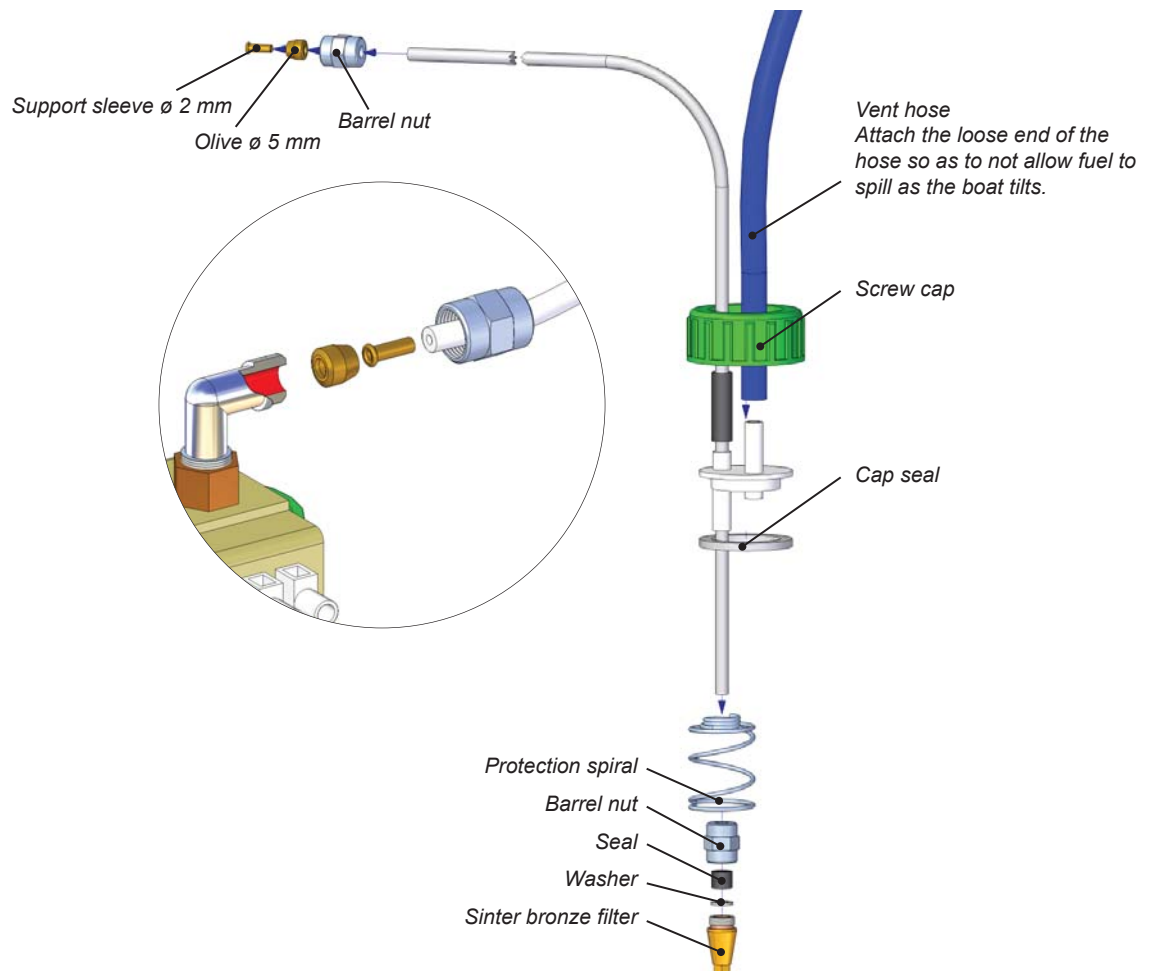

Tank-external filters

Filters can be installed in a $\varnothing 5$ or $\varnothing 6$ mm plastic or $1/8$ " metal pipe. Ensure that the fuel pipes are clean before installing the filter. There must be no debris or impurities between the pump and the filter as they will clog the pump. The filter type must be selected according to the operating conditions and country-specific requirements.

Fuel filter 30015

The filter is supplied with the stove.

The filter can be installed directly in the **30011** tank connection by using a $\varnothing 6$ mm rubber hose (1) and 10 mm hose binders (2).

Alternatively, the filter can be installed between two $\varnothing 5$ mm fuel hoses with $\varnothing 5$ mm rubber hose (3) and $\varnothing 8$ mm hose binders (4).

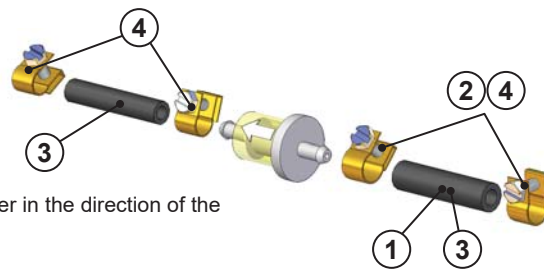
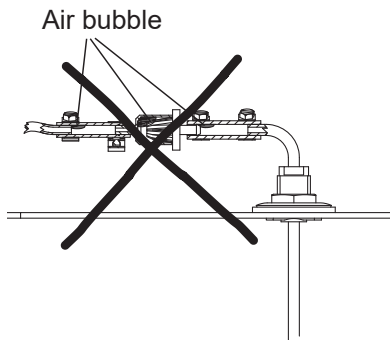

Install the filter in the direction of the arrow on it.

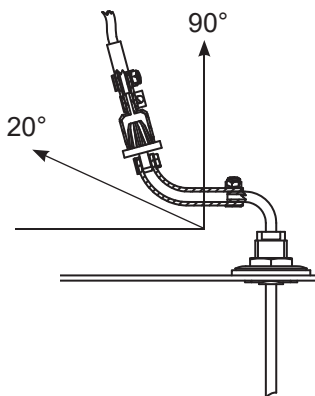

Fuel filter 30014 (accessory)

This filter is intended for cold conditions.

The filter can be installed directly in the **30011** tank connection by using a $\varnothing 6$ mm barrel nut and 6 mm olive.

Alternatively, the filter can be installed between two $\varnothing 5$ mm fuel hoses with $\varnothing 5$ mm barrel nut, $\varnothing 5$ mm olive and $\varnothing 2$ mm support sleeve.

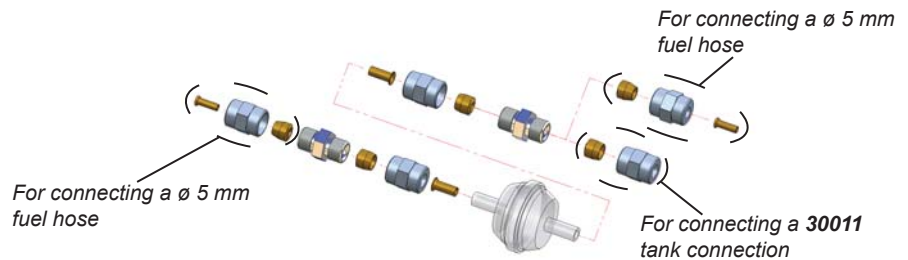

Fuel filter 30016 (accessory)

Used in countries where a metallic fuel transfer system is required. A $1/8$ " metal pipe is used for the installation.

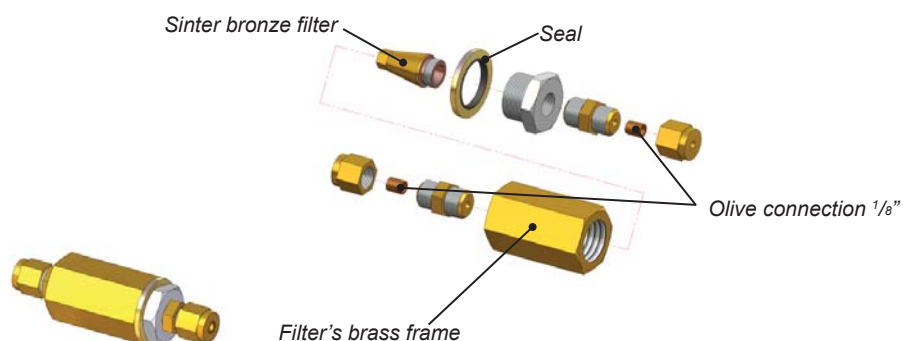

Installation instructions for Solenoid valve 30012 (accessory)

The solenoid valve **30012** prevents the tank from emptying in case the fuel line breaks.

The fuel filter should be installed before the solenoid valve.

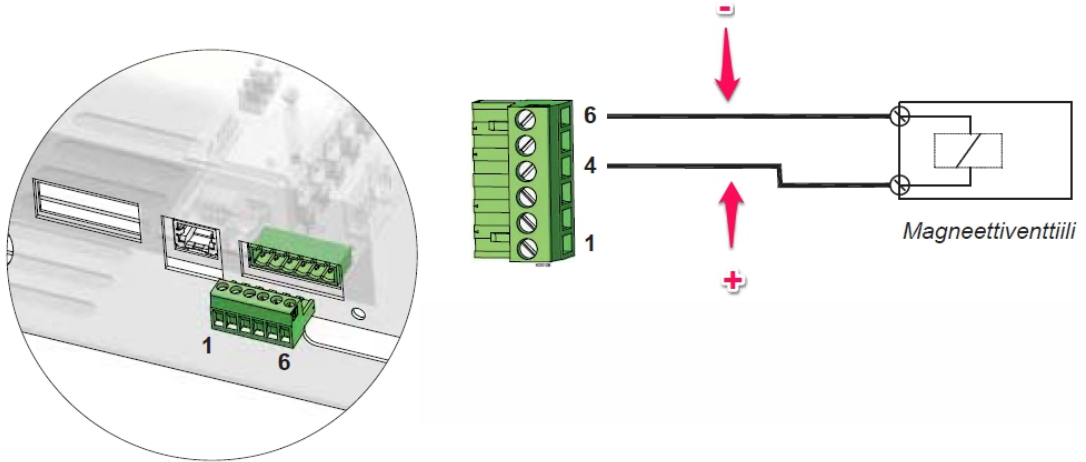

Solenoid valve connection to the circuit board

Our recommendations in the following installation scenarios:

1. Fuel level is below the heater/stove.

Picture 1.

- Recommended installation scenario
- No special accessories required

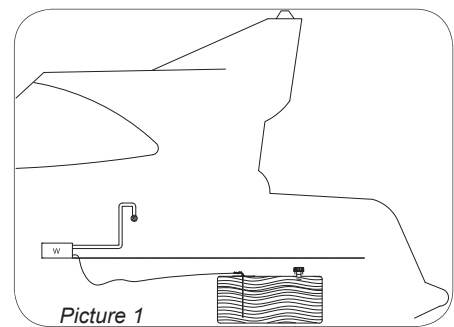

2. Fuel level may temporarily rise above the heater/stove (e.g. in the fuel tank filler pipe or when the boat tilts).

Picture 2.

- No special accessories required

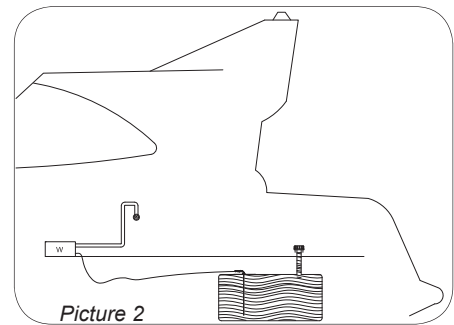

3. Fuel level is above the heater/stove.

Picture 3.

- Non-recommended installation scenario
- Solenoid valve **30012** must be installed in the fuel hose near the tank.

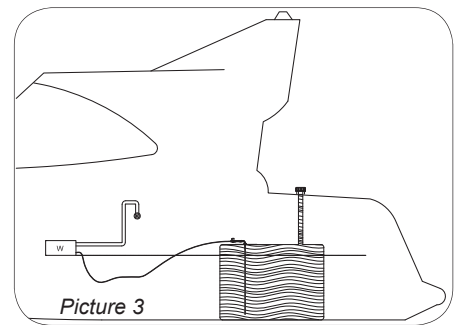

If the fuel level in the tank is above the device, a solenoid valve **30012** must be installed in the fuel line immediately after the tank lead-through.

Selecting the fuel

When selecting the fuel type, take note of the temperature limits of each particular fuel. The limit values provided here are to be treated as guidelines. Confirm the actual temperature limits from the fuel supplier.

- light furnace oil / diesel, summer grade, temperature must not fall below $-5\text{ }^{\circ}\text{C}$.
- light furnace oil / diesel, winter grade, temperature must not fall below $-24\text{ }^{\circ}\text{C}$.
- light furnace oil / diesel, arctic winter grade, temperature must not fall below $-40\text{ }^{\circ}\text{C}$.

If the temperature drops lower than the minimum level, paraffin may form in the fuel. This may result in the fuel filter and pump being clogged. The clog will dissolve only if the fuel temperature rises clearly over $0\text{ }^{\circ}\text{C}$.

The less aromatic substances the fuel contains, the less deposits will be formed. Normal furnace oils contain 35–40 % of aromatic substances. In city diesels and green furnace oils the concentration is 20 %.



Confirm the actual temperature limits for the fuel you are using from the fuel supplier.

Exhaust gas connections

Exhaust gas lead-throughs

Exhaust gas lead-throughs 2467, 5400 and the closable model 2460 are suitable for device. The \varnothing 28/45 mm lead-throughs fit the exhaust gas pipe 2448.

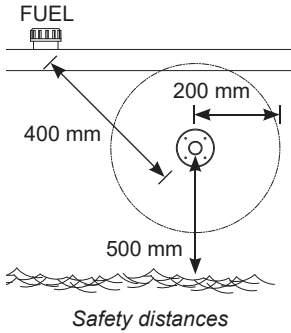

All exhaust gas lead-throughs are stainless steel.

General instructions for exhaust gas connections

Location

Air must always flow freely past the lead-through. Install the lead-through on a flat surface. Avoid corners or recessions where wind pressure can disturb the functioning of the device.

The minimum distance of the lead-through from the fuel tank's filler hole is 400 mm (16").

The minimum distance of the side lead-through from the surface of the water is 500 mm (20"). Especially in sail boats it should be noted that the lead-through must never be submerged.

It is recommended to place the lead-through in the side as far back as possible or directly in the transom.

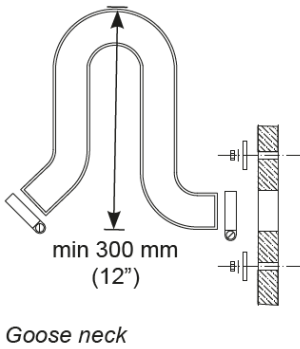

INSTALLATION

When preparing the installation cut-out for the lead-through, it is a good idea to use the lead-through as a model for the cut-out; especially if the lead-through is circular. If necessary, seal the installation cut-out with silicone in addition to the lead-through seal. Note! Do not use silicone on a wooden boat.

The side lead-through must always be equipped with a so-called goose neck section. The goose neck will effectively prevent splash water from getting to the device. The highest point of the goose neck must always be above the surface of the water.

The device will go out, if the exhaust gas lead through is submerged.

OTHER THINGS TO NOTE

Exhaust gas is hot. Always ensure that there is nothing that is susceptible to heat damage within 200 mm (8") of the effective area of the exhaust gases (e.g. ropes, fenders or the side of another boat).

All lead-throughs raise the temperature of their surroundings. A wooden deck, in particular, may dry due to the heat. Remember that the surface of the lead-through is hot during use.

The exhaust gas pipe must be made of stainless steel.

If necessary, seal the connections between the exhaust gas pipe and the lead-through with heat-resistant silicone.

When installing the lead-through to the stern side or to otherwise leaning position, be sure that the water do not stuck the exhaust. Drill app. 2 mm (3/32") hole to the lead-through or to the exhaust pipe

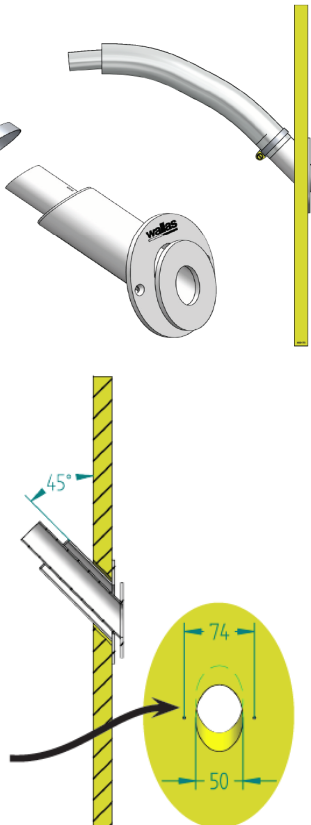

Mounting of the transom feedthrough

Insulation kits

Insulation kit for a metal-hulled boat

An insulation kit must be used to insulate the lead-through from the boat's metal hull.

The insulation kit insulates the exhaust gas lead-through and the device from each other.

In fault situations the electric circuit runs between the metal hull and the device.

This can result in the oxidation or malfunctioning of the device's circuit board, the circuit board may be damaged.

Insulation kit 2461 for circular coaxial lead-throughs (2467 and 2460)

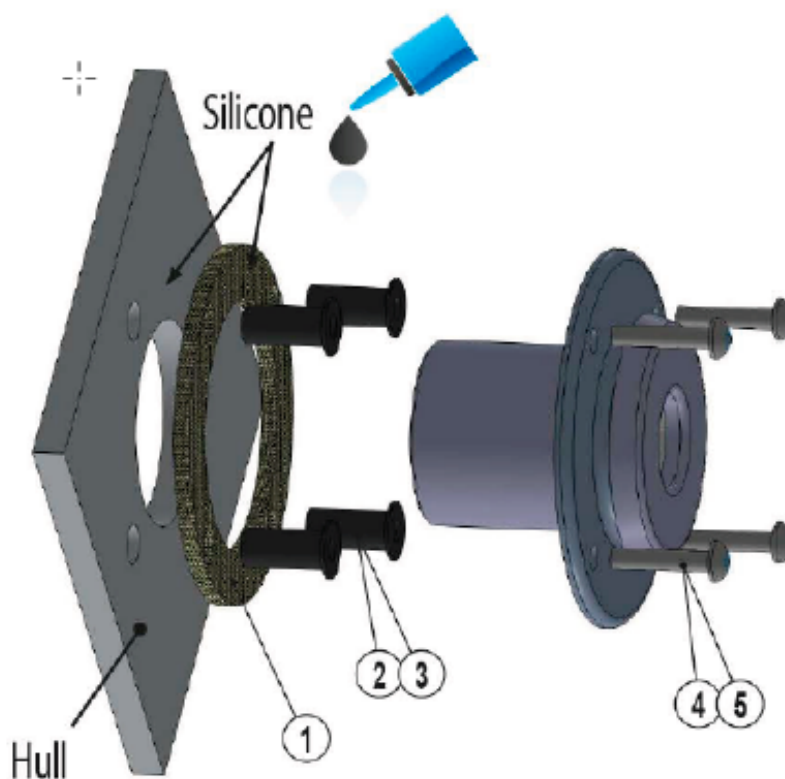

Package contents

2461B		
①	2 pcs	Gasket, 2461
②	4 pcs	Rubnut M5x0,8x21,5
③	4 pcs	Rubnut M5x0,8x39,8
④	4 pcs	Screw M5x25 A2
⑤	4 pcs	Screw M5x40 A2
	1 pcs	Installation Instructions / Insulation kit 2461B

Specific instructions for individual lead-throughs

Side lead-through 2467

A side lead-through is installed in the side of the boat or in the transom. In sail boats it is recommended to install it in the transom. The installation always requires a so-called goose neck piece.

Make the necessary installation cut-outs and spread a suitable sealing agent on both sides of the seal and on the screw holes. This will ensure that the connection is waterproof.

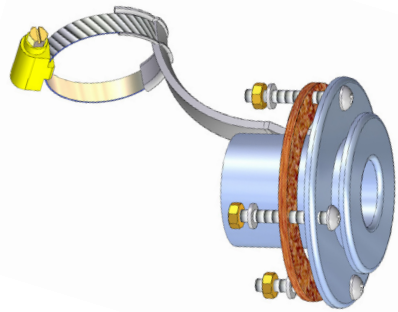

2467 Side lead-through

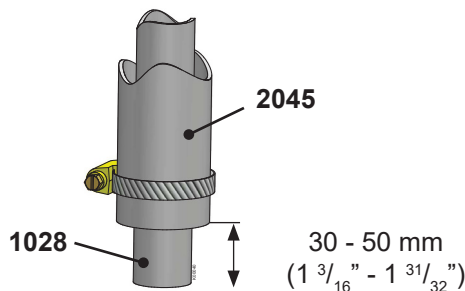

Length difference of the pipes

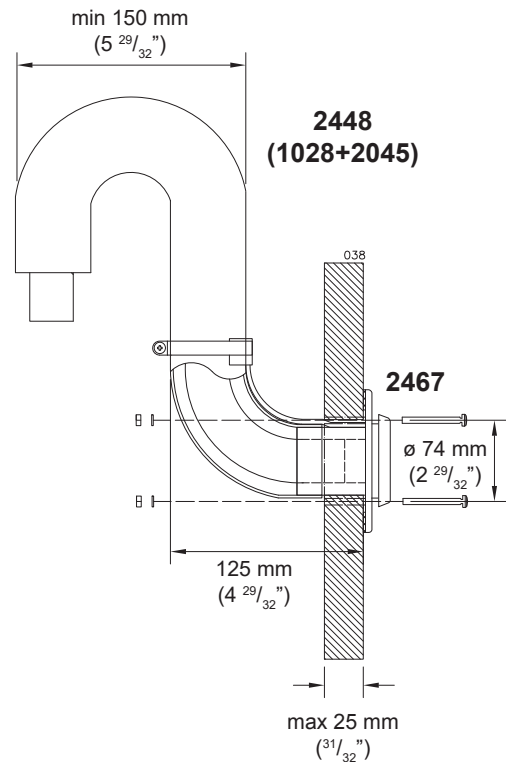

Side lead-through 2467 installed.
The installation cut-out is $\varnothing 50$ mm (1 31/32") and the screw holes are 4 x $\varnothing 6$ mm.



The 1028 exhaust gas pipe must be 30–50 mm (1 3/16" - 1 31/32") longer than the 2045 inlet pipe. This way the exhaust gas pipe will stay in the overall length of the piping. . The measurement depends on

Package contents

2467	
1 pcs	Side lead-through
1 pcs	Accessory bag 17679
4 pcs	Fastening screw M5 x 40 mm
4 pcs	Nut M5
4 pcs	Washer 5,3 x 10 mm
1 pcs	Hose clamp 32 - 50 mm
1 pcs	Gasket

Closable lead-through 2460

The cap of the closable lead-through must be detached for installation and seal maintenance by pressing the spring indicated by the arrow in with, for instance, a screwdriver. Take care not to let the screwdriver slip as the spring is very stiff. Hold the cap with your other hand when pressing in the spring. When the spring is down, pull the cap gently out of the frame. When assembling the lead-through, ensure that the order of the parts is correct. Also make sure that the spring goes in the correct hole in the cap. Otherwise, the lead-through cannot be closed.

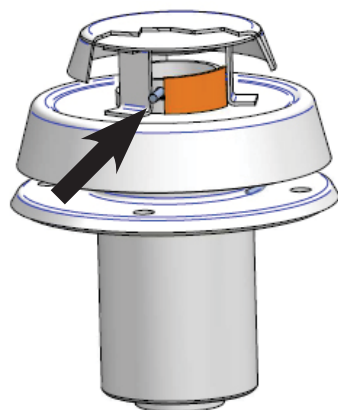

2466
Closable lead-through.

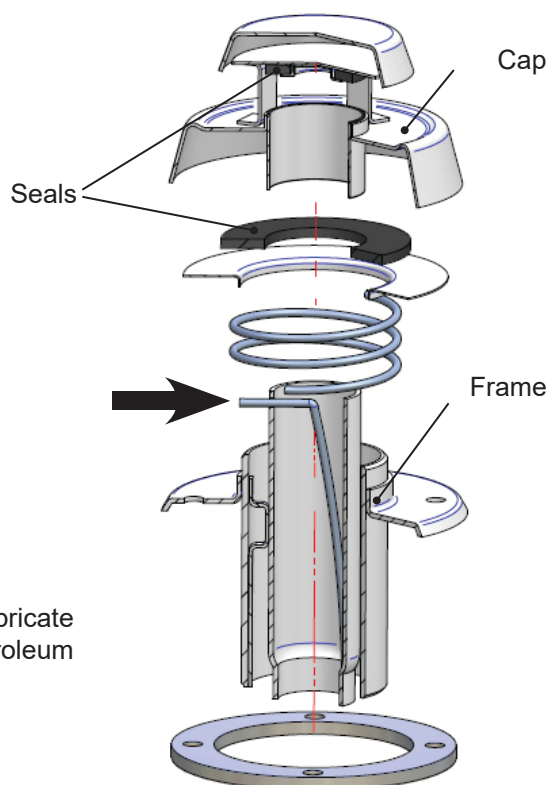

Maintenance

To keep the seals from hardening, lubricate them yearly with a heat-resistant petroleum jelly.



Check that closeable fitting is open before starting the device.

Package contents

2460	
1 pcs	Closable lead-through
1 pcs Accessory bag 17678	
4 pcs	Fastening screw M5 x 85 mm
8 pcs	Nut M5
4 pcs	Washer 5,3 x 15 mm
4 pcs	Washer 5,3 x 10 mm
1 pcs	Hose binder 20 - 32 mm
1 pcs	Hose binder 32 - 50 mm
1 pcs	Gasket

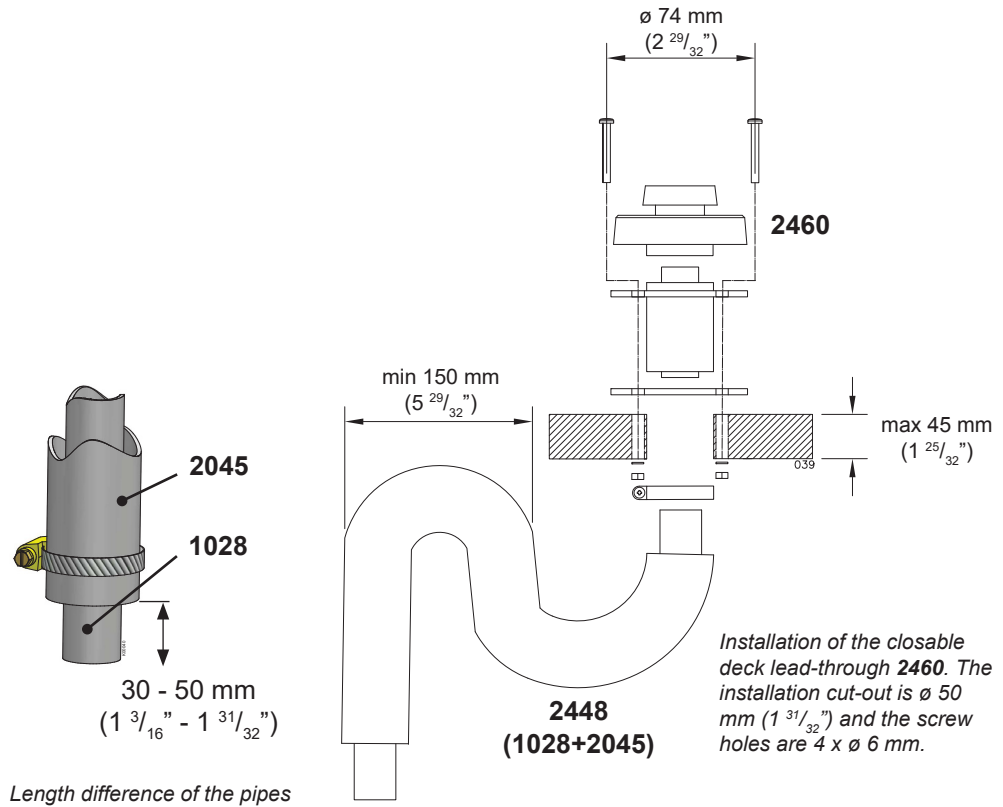

The 1028 exhaust gas pipe must be 30–50 mm ($1 \frac{3}{16} \text{ \"} - 1 \frac{31}{32} \text{ \"}$) longer than the 2045 inlet pipe. This way the exhaust gas pipe will stay in place in the lead-through more . The measurement depends on the overall length of the piping.

Cooling fan 30019

Cooling fan accessory 30019 has to be used with 220 blower lid. This cooling fan takes air from the space below the stove.

Cooling fan has to be installed in the place where it blows coming warm air in the ventilated space.

The warm air can be lead, for example, according to this picture or behind the installation cabinet if it is ventilated space.

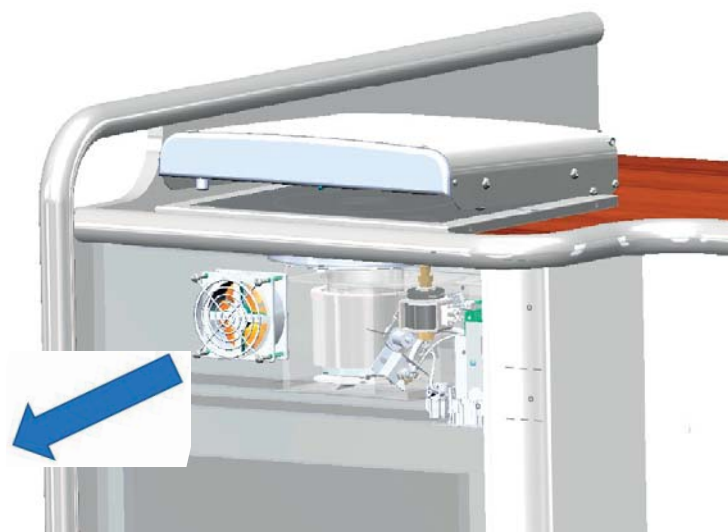

Installation and initial start-up

Installation

- Ensure sufficient air ventilation for heater, minimum aperture of 100 / 150 cm² (16 / 24 sq. in.) into installation area.
- Ensure that the boat is sufficiently ventilated.
- The exhaust pipe outlet must be at least 400 mm (16") away from the opening for filling fuel or tank breather.
- We recommend installing the operating switch on a vertical surface where liquids are not able to leak into the switch and it is out of reach of children (cable length 3 m).

Fuel system

- Fuel for the device comes through a separate tank fitting, not via a manifold or connection shared by the engine or other device.
- Install the filter to the fuel hose before you install the device, in an accessible location for filter changes.
- Fasten the fuel hose couplings tightly.** Always use a sleeve joint on the hose (olive ring).
- Make sure that the surfaces of the couplings are clean before fastening them.
- The hoses must be kept clean during installation.
- Use only Wallas fuel hoses.
- If the surface of the fuel tank is above the device, a magnetic valve must be installed into the fuel hose close to the tank.
- Cut the fuel hoses to the appropriate length when installing them.

Electrical installation

- The nominal voltage of the device is 12 VDC.
- Current for the device is taken directly from the battery terminals using cables that are as short as possible.
- Put the main fuse of c. 15 A on the + cable close to the battery.

Exhaust fumes

- When choosing the outlet location, note that exhaust fumes are hot.
- Use a goose-neck to prevent splash water entering the boat from splashing into the outlet.
- If your boat has a metal hull, the device and outlet must be insulated from the hull to prevent electrochemical corrosion.
- The exhaust pipe must not come into contact with combustible materials. Insulate the exhaust hose, if necessary.

Initial start-up

The device usually does not start the first time after it has been installed. It may take several starts (c. 4-6) for the fuel hoses to fill up enough for the fuel to reach the burner.

Watch the hoses as they fill up as you start the device.

After two unsuccessful start-ups, the device will lock. (The yellow and red LED lamps will blink simultaneously indicating a lock-up.)

Follow the instruction for unlocking the device and try again.

Watch the hoses fill up with fuel while you start the device.

When the device starts, look for possible leaks in the exhaust and fuel connections.

Run the device for c. ½ hour to allow possible installation and manufacturing greases to burn off. Make sure there is enough ventilation.



Remember to carefully read the instructions for installing, operating and servicing each device before installation.

To be filled in by the installer

- Test-run performed

Serial number	
Company	
Installer	
Installation date	
Signed	

Installer must check (x) the sections, then sign her/his signature.

Device use

Ignition

The stove turns on and heats automatically.

The stove turns on when the power switch (3) is continuously pressed for at least 2 seconds, and the power indicator light (4) turns on, notifying that the stove is ready for use. The stove switches to its normal mode when the switch is released after 2 seconds of pressing and the yellow heating indicator light (7) turns on. When the switch is released, the device will, alternatively, switch to a high altitude mode after 10 seconds.

A red combustion indicator light (1) will be lit when the burner flame has been ignited and the combustion has stabilised after about five minutes after the ignition. The whole process takes about 11 minutes.

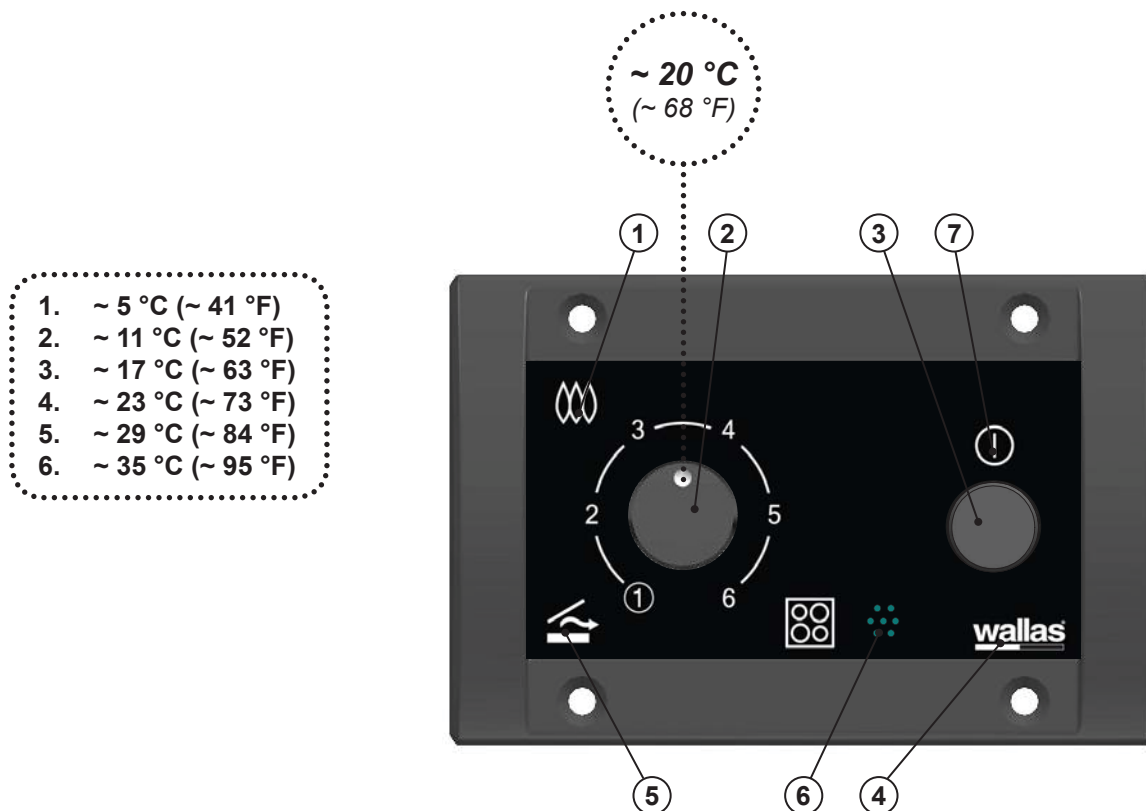

- | | |
|---|-------------------------|
| 1. Combustion indicator | 5. Thermostat indicator |
| 2. Temperature adjustment / Power control | 6. Thermostat sensor |
| 3. Heating switch | 7. Heating indicator |
| 4. Power indicator | |

First start-up

After installation or maintenance, if the fuel line is empty, the heater may not start at the the first attempt. Start-up phase with empty fuel line is longer than normally and might take about 15 minutes. If the heater doesn't ignite the red combustion indicator light will start to blink after start-up.

Turn off the heater. The device cannot be restarted until the cooling phase is completed.

When the cooling phase is finished, switch the heater on again.

If the device does not start after two attempts, it cannot be started again: the heater will lock itself (lights blink to indicate this). Find out the reason why the unit didn't start.

If the heater ignites during two attempts the red combustion indicator (1) will go on.

After locating the fault, release the locking (instructions in the maintenance section) and start-up the unit.

Depending on the length of the fuel hose, the heater may have to be started up several times during priming. Keep an eye on how the fuel travels in the fuel hose while starting up the heater.

Normal Use

The power is adjusted manually. The cooker will always ignite in manual mode.

After the ignition power can be adjusted step-less with the power control (2) knob. Avoid turning the power control knob rapidly back and forth, this may cause the burner to become sooty.

When using as a stove, make sure that the thermostat indicator light (5) is not on.

Cooker used as a heater, thermostat use

Requires a heat blower lid (accessory).



Automatic power adjustment, thermostat controlled adjustment.

Is used only with a heat blower lid when the lid is folded over the ceramic top.

The function can be activated/deactivated whenever wanted. Turn the power control knob (2) to positions min-max-min-max when yellow heating indicator (7) is on, to activate the function. As a confirmation of the mode change, the thermostat light (5) will be lit.

When turning again the power control knob (2) min-max-min-max, the thermostat light (5) will go off and the unit returns to manual mode.

After the cooker has passed the ignition phase, the temperature is adjusted by turning the power control knob (2). The power control knob is turned to the required position.

When the thermostat light (5) is bright, the temperature is below the required temperature – the effect is increased. When the thermostat light (5) dims the required temperature is achieved.



The total time of the starting procedure is app. 11 minutes, when after the device can be adjusted or will set itself to the selected effect.

Sun-switch (heating)

The sun-switch shuts down the device automatically, if the temperature rises above the requested temperature, for example, due to sunlight. The temperature must rise by +3 °C above the set value for a half an hour. If the device has been shut down by the sun-switch, an indicator light (5) blinks on the thermostat. The sun-switch can be turned off temporarily, by turning the temperature control (2). A heater that has been shut down can be restarted manually, if necessary.

Conservation temperature

The temperature control (2) is set to minimum, and the cabin is maintained at a temperature of +2 – +8 °C. The sun-switch is not enabled in this mode.



Temperature of cabin can be determined by turning the knob (2) until the brightness of the thermostat light (5) changes. The position of knob (2) when the light changes will indicate cabin temperature.

Manual power adjustment (stove/heating)

The power can be adjusted manually.

To enable this function, turn the power adjuster (2) to positions min - max - min – max.

The device signals that manual function has been activated when the thermostat light (5) shuts off.

After the heater has been started up, the power can be adjusted smoothly with the power adjustment knob (2).

From manual mode to thermostat mode you can go by turning the knob (2) min - max - min – max. As a confirmation of mode change the thermostat light (5) will go on

Shutdown

You can shut down the heater by pressing the heating switch (3) continuously for at least 2 seconds. The yellow heating indicator light (7) will go out immediately. The red combustion indicator light (1) will continue to blink for about five minutes, while the device is cooling down. You cannot restart the device until the combustion light has stopped blinking.







When adjusting the effect from the regulation knob, the effect adjusts smoothly.











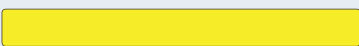

High altitude switch

Switch for high altitudes. Switched on when the device is used more than 1500 meters above sea level. This function increases the amount of combustion air in thin air.

The high altitude mode is turned on by pressing the heating switch (3) for 10 seconds. As a sign of the switch being on, the yellow heating indicator light (7) will flash three times.

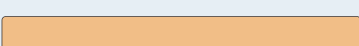
Colour	Blink interval	Function
Yellow	  2 s.	Heating on Pressing for 2 seconds starts the device in its normal mode.
Yellow	  10 s.	Heating on Pressing for 10 seconds switches the device to a high altitude mode.

Signal lights

Colour	Blink interval	Function
Yellow	 	Heating on
Red	 	Combustion indicator when the combustion has begun normally
Red	 	Aftercooling
Orange	 	Thermostat control, the set temperature exceeds the set value > power is increasing
Orange	 	Thermostat control, the set temperature is lower than the set value > power is decreasing
Orange	  30 s 	Sun switch has shut down the device

Things to note about the use of the cooking plate

Only use dishes with a smooth bottom so as to not damage the stove top. If you use the cold stove top for other work or chores, be sure to wipe it clean thoroughly after you are done. Even a small crumb, if hard enough, can scratch the surface when a kettle is placed on the stove top. These small scratches, which are to some extent inevitable, will in no way affect the heating power of the stove.

The bottom of the cooking vessel should be slightly concave when cold so that when it expands due to the heat, it will sit evenly on the stove top and the heat energy will be distributed optimally.

The ideal bottom thickness for steel enamel vessels is 2–3 mm and for steel kettles with a sandwich bottom 4–6 mm.

Cleaning and maintaining the stove top

In order to keep the stove top in good condition both aesthetically and performance-wise, it should be cleaned regularly; preferably after each time of use. First scrape of the clearly noticeable dirt and food scraps with a cleaning spatula. Put a few drops of a cleaning agent for ceramic surfaces on the stove top and wipe it with a piece of kitchen paper. Then wipe the stove top with a moist cloth and dry it with another cloth. Do not use abrasive cleaning sponges or agents. Additionally, avoid using chemically strong cleaning agents, such as an oven cleaning spray or stain remover.

Immediately clean off aluminium foil, plastic, sugar or other sugary substances that have melted on the stove top. This prevents the surface from getting damaged. Before cooking particularly sugary foods, the surface should be treated with a protective agent. This prevents possible damage due to the food boiling over.

Observe the general maintenance recommendations for Wallas equipment when servicing the electronic and mechanical parts of the stove.



Never keep the stove on without a kettle or closed blower lid.



When leaving the yacht always check that the cooker has not been left on.

Fault signals and releasing the lock

Colour	Blink interval	Fault description
Yellow	2 s 2 s	Glow failure
Yellow	2 s	Combustion air blower fault
Yellow	2 s	Main blower fault
Yellow		Undervoltage
Yellow Red	Locking; the device locks itself after 2 unsuccessful starts *)	
Red		Indicating flameout
Yellow Red	Overheat	
Red	30 s	5 minutes after fault indication



If the heater has locked itself, you must determine the cause for the locking before releasing it.



***) RELEASING THE LOCK:**

1. When the lights are blinking, switch off the main power at the battery (we recommend removing the fuse), breaker or in-line switch.
2. Switch the main power back on.
3. Press the power switch (3) for at least 2 seconds.
The yellow heating indicator (7) will light for 1-3 seconds.
4. Press the power switch (3) again for at least 2 seconds. *The heater is turned off. Power indicator light (4) will shut down.*
5. Restart the heater normally.

Maintenance recommendations

Basic maintenance of diesel-operated devices

Maintenance procedure	Maintenance interval	Carried out by
First inspection of basic functions	Inspection after first 500 hours of use or the first season of use	Authorised Wallas service shop
Cleaning the burner	The service shop recommends a suitable maintenance interval after performing the inspection of basic functions.	Authorised Wallas service shop

Special recommendations

Occasional (monthly) use of the device will increase reliability by purging old fuel.

If the device uses the same tank as the engine:

Observe the engine manufacturer's recommendation with regard to the fuel type and moisture removal.

If the device has a separate tank:

When selecting the fuel type, take note of the temperature limits of each particular fuel.

Removal of the water from the tank

Isopropanol based anti ice detergent meant for gasoline cars (no ethylene or methyl based) will be added to the fuel during the season. It is useful to make the addition after each couple of tanks and in the beginning and end of the heating season. The anti ice detergent binds the condensed water and prevents the sediment and contamination during the summer. For the dosage, observe the recommendations given by the manufacturer of the agent.

Winter storage

If the device uses the same tank as the engine:

- Change the fuel filter.
- Perform measures recommended by the boat/engine manufacturer to be performed before winter storage.

If the device has a separate tank:

- Drain the fuel tank in the autumn.
- Clean the tank and change the fuel filter.
- Fill the fuel tank with fresh and clean fuel in the spring.

For the device itself, you do not need to do anything.

Spare parts

Spare parts list, www.wallas.com



An anti-freezing agent for diesel vehicles may increase the forming of scale at the bottom of the burner and therefore shorten the maintenance interval.

Troubleshooting, locking indication

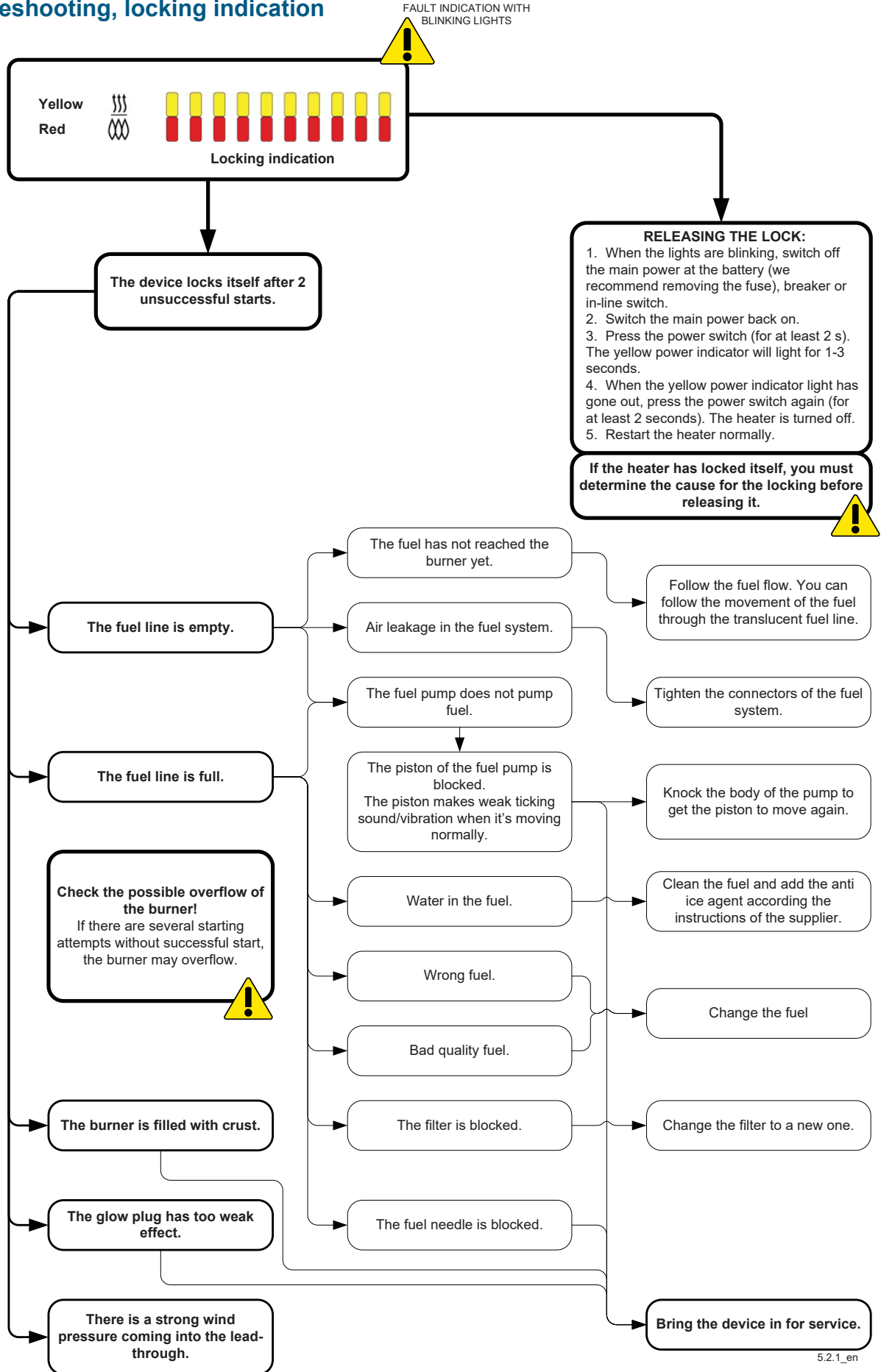

Troubleshooting, undervoltage

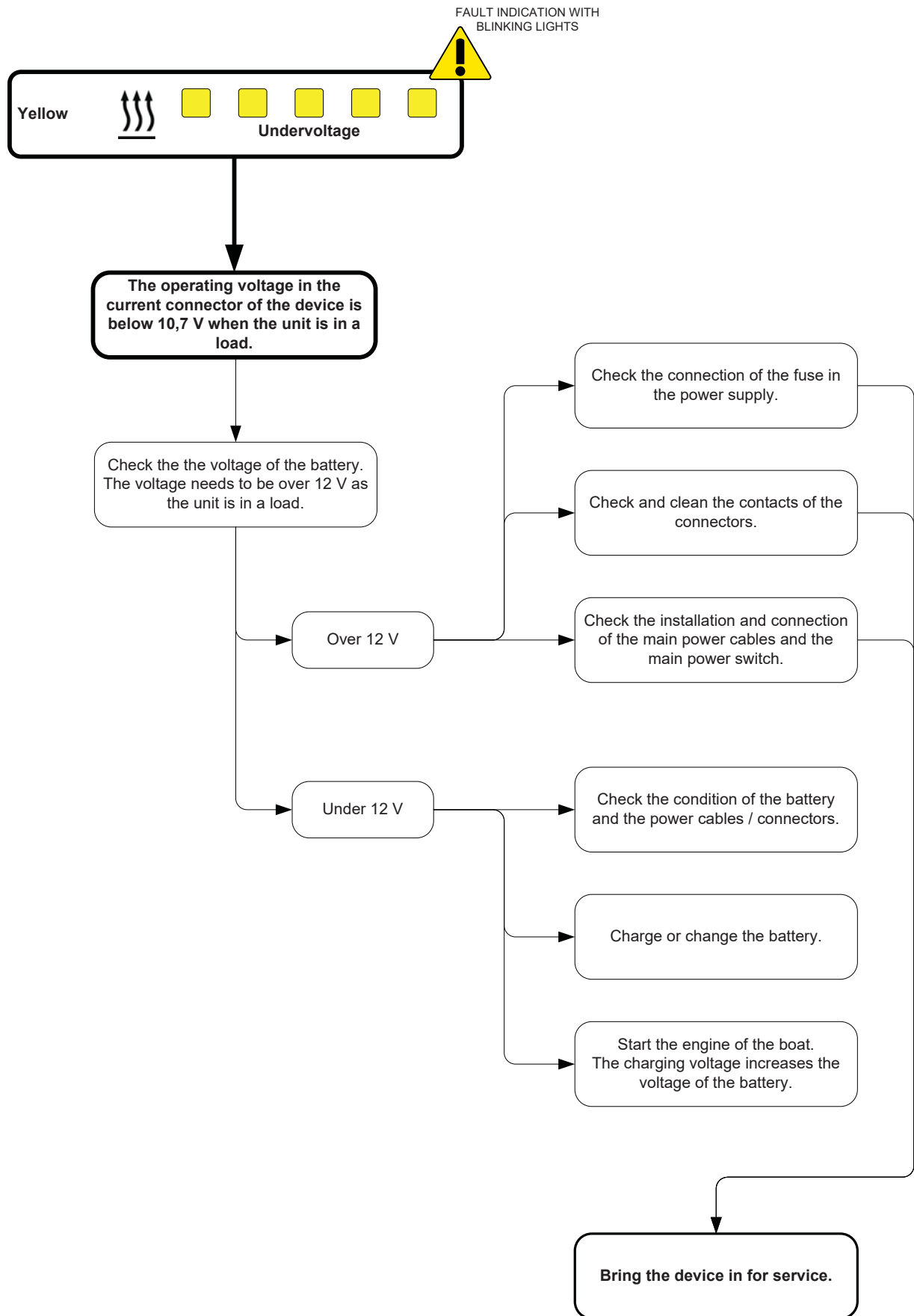

4.1.2_en

Troubleshooting, indicating flameout / overheat

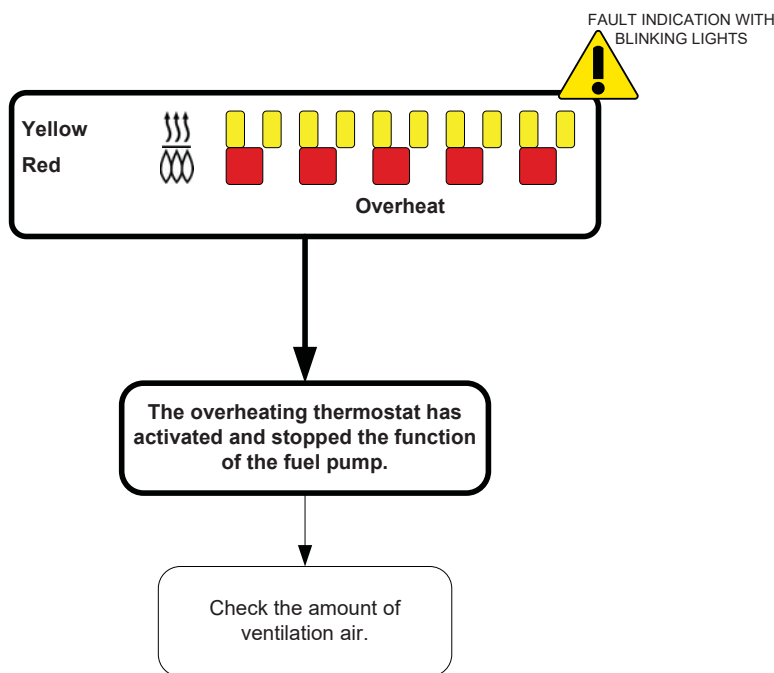
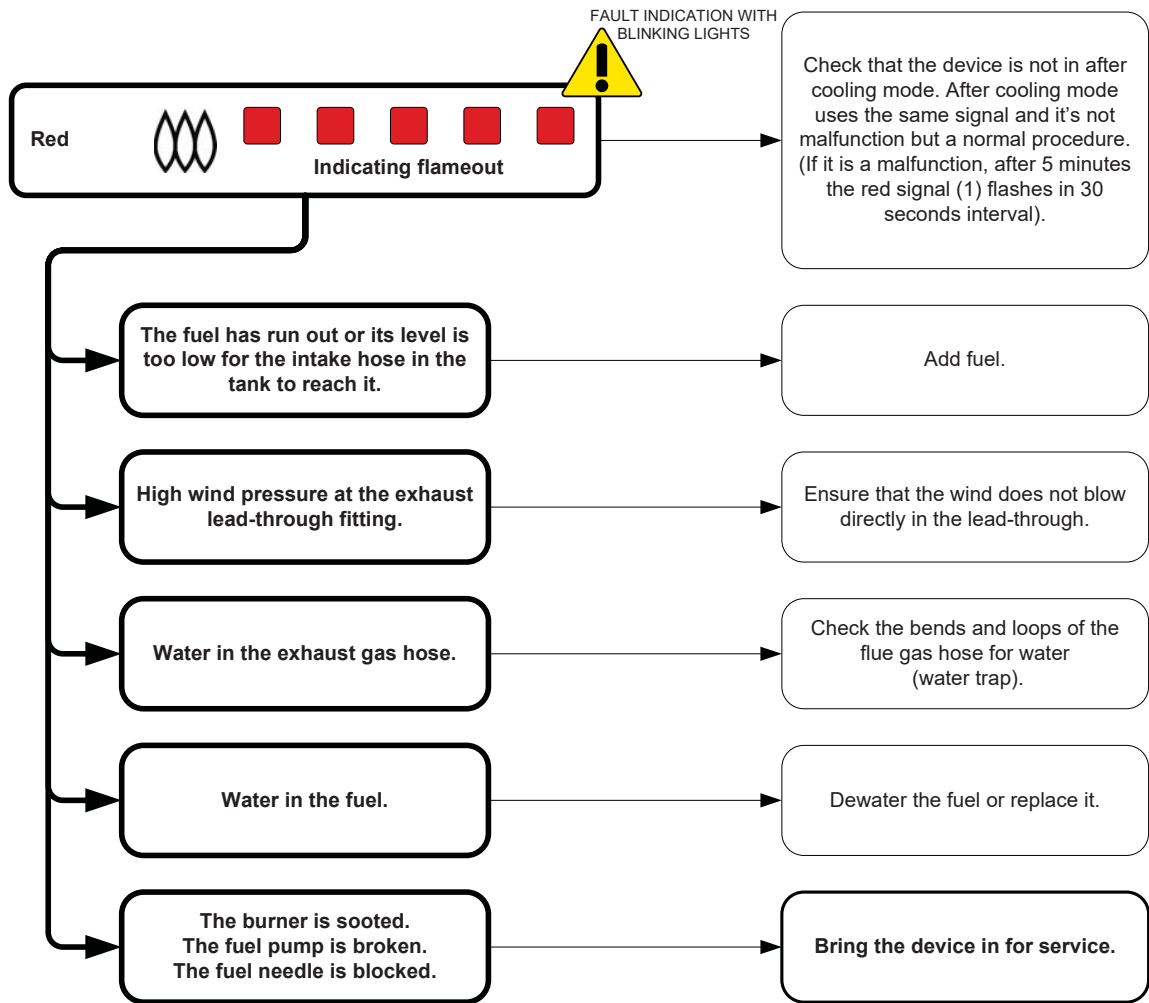

5.0.3_en



Wallas-Marin Oy (the manufacturer) shall be liable for any defects in the raw material or manufacture of the products and items sold by the importer for 24 months from the day of sale on the following conditions.

Warranty can be extended by a further 12 months by registering the product in the website of Wallas-Marin Oy (www.wallas.fi) within three (3) months of the unit being sold to the end customer.

1. In the event of a defect:
 - a) Look at the check list on the website or installation / usage manual (www.wallas.fi) to make sure the defect in question is not related to use. A simple problem might not be covered by the warranty ie. water in diesel or unit requires a service.
 - b) Notification of the defect must be given in writing immediately, if possible, but no later than two (2) months after the appearance of the defect. After the warranty period ends, a referral back to a notification at the time of the warranty period is not valid unless the notification was made in writing. A valid receipt or another reliable official document of the time of purchase is required for proof of warranty eligibility.
 - c) For repairs under warranty, the customer must take the product to the place of purchase (the seller is responsible for handling units with warranty issues), to an authorized repair shop or to Wallas-Marin Oy factory service. Warranty service must be done by authorized Wallas repair personnel. The warranty does not cover costs for the removal and reinstallation of the device or for any damage in transit of a device that has been sent for repair. Warranty does not include any transport costs. (Wallas is a return to base warranty).
 - d) The customer must provide the following information in writing for warranty service:
 - description of the problem.
 - a description of where and how the device was installed (photographs of the installation may help)
 - product type and serial number, place and date of purchase
2. This warranty is not valid in the following cases when:
 - failure occurs as a result of components, which are not approved by the manufacturer, have been added to the device, and/or, its structure has been modified without the consent of the manufacturer.
 - the instructions for installation, operation or maintenance have not been followed.
 - storage or transport has been inappropriate.
 - a problem has resulted from an accident or damage, which Wallas has had no control over (force majeure).
 - problems arise from normal wear and tear. Wearing parts include: glow coil/plug, combustion / blower motors (warranty limit 2000 running hours), bottom matt, fuel needle, fuel pump and fuel filter, seals
 - the product has suffered from improper handling, unsuitable fuel, low voltage, excess voltage, damage due to dirt, water penetrating in to the unit or corrosion
 - the device has been opened without the explicit permission of the factory/importer
 - components, other than original Wallas spare parts or components, have been used in the repair of the device.
 - repair by unauthorized service company
3. Repairs carried out during the warranty period do not renew or alter the original warranty period.
4. Indirect damages arising from a defective product are not covered by this warranty.
5. This warranty is only valid for boat products that have been installed in boats and for cottage products that have been installed in cottages. The warranty does not cover Wallas products installed in vehicles or other areas.
6. This warranty does not limit rights specified in consumer protection legislation.
7. 2+1 year warranty applies to the equipment produced within the last 5 years.



When making a warranty claim, the customer must provide proof that the maintenance and safety instructions have been thoroughly followed. This warranty does not apply to defects which have arisen due to carelessness in following installation, operation and maintenance instructions.