

Thule Vent & Thule Vent 12V

› Instructions

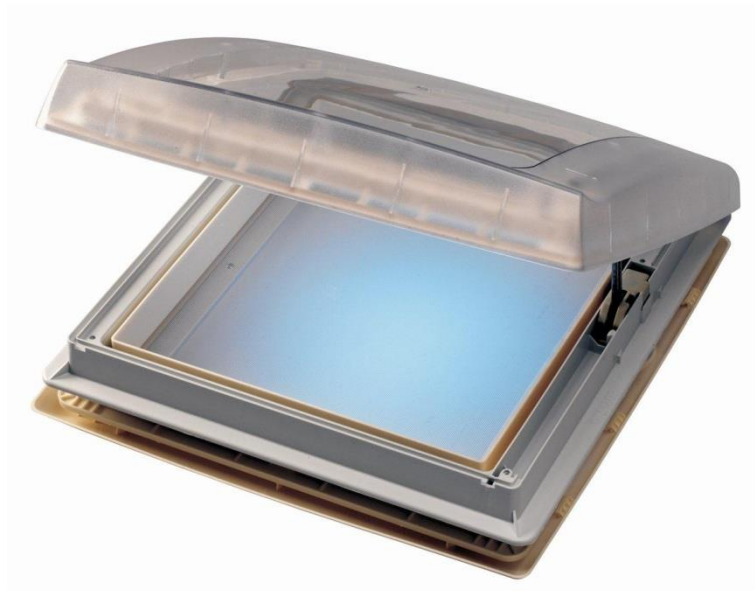

Thule Vent & Thule Vent 12V

DL921-09



Read these instructions carefully. No guarantee will be allowed for wrong installation.

INSTALLATION AND USE OF THE ROOFLIGHT

CONTENTS MOUNTING SET

a. Mounting clip.....	4
b. Screw DIN 7982 - 4,2 x 38.....	4
c. Washer DIN 125 - M5.....	4
d. Screw DIN 7981 - 4,2 x 38.....	4
e. Operating knob	1
f. Square shaft 6 x 70 mm.....	1
g. O ring 10x3.....	1
h. Extension tube 15mm.....	4
j. Screw DIN 7981 - 3,5 x 9,5.....	2

INSTALLATION ROOFLIGHT (fig.1)

To install the Thule Vent a roof thickness of 25 to 60 mm is required.

1. Make a 402 x 402 ± 1 mm opening and clean the surrounding area (fig.2).
2. Place an acid free sealing material that sticks to A.B.S. under the edge of the upper frame (C) (fig. 3).
3. Install the upper part (A+C) with the hinge in the driving direction.
4. Fix the exterior frame to the roof by using the mounting clip (a) in the middle of each side (see fig. 4). Use screw DIN 7982 - 4,2 mm with length according to the table. The mounting clip must be positioned against the edge of the cut out (fig. 6). Do not over tighten, so that no deformation of the frame can occur.
5. For Thule Vent 12V, with ventilator: Connect 12V DC to the lead-in wires of the ventilator as described below (fig.17).
6. Put the operating knob with the square shaft into the inner frame (D) and secure it with the O-ring (fig. 9).
Remark: The supplied operating knob with square shaft is suitable for roof thicknesses from 25 up to 50 mm. For a roof thickness over 50 mm, use the kit for roof thickness 40-60mm with a square shaft of 90 mm length. See at options.
7. Install the inner frame (D) with the square shaft of the knob in the hole of the mechanism. For a roof thickness ≥ 40mm, put first on the screw tube in each corner of the exterior frame (C) an extension tube (h). This will make the screwing of the interior frame easier (fig. 7).
8. Fix the interior frame (D) to the exterior frame (C) in the corners by using the screws DIN 7981 - 4,2mm with length according to the table (fig. 5).
9. Click the frame with the roller blind (G) to the interior frame and secure it with two screws DIN 7981 3,5 x 9,5 (fig. 10/1-4).

USE ROOFLIGHT

- Close the lid before driving.
- To take away the roller blind, unscrew and click the frame off at the side of the knob.

OPTIONS

- 12V fan. Prod.nr. 211001.
- Kit for roof thickness 40-60mm. Prod. nr. 308226.

INSTALLATION AND USE OF THE VENTILATOR

INSTALLATION OF THE VENTILATOR

A ventilator 12V - 20 min³/min (700 cft/min.) can be installed afterwards to the Thule Vent roof light.

1. Take off the curtain frame and the inner frame (fig. 11). Remove the mosquito roller from the curtain frame (fig. 12).
2. Open the lid to take away the lock (if fitted). Then unscrew the three (torx) screws closest to the lock and screw them back afterwards. See fig. 13.
3. Put the ventilator kit through the opening and clip it into the outer frame. The clips with the two ribs should be at the side with the hinge (fig. 14).

4. It is possible to connect an external thermostat or proximity switch to the ventilator. Unscrew the grid and unclip the control panel. Put the two wires of the switch into the connector marked 'thermo' with the help of a flat screwdriver. Refit the panel and the grid (fig. 15).
5. Connect 12V DC to the lead-in wires of the ventilator via a slow fuse of 10A in the + conduction and the main switch with 1,5mm² wires. The red wire: positive \oplus , black wire: negative \ominus (fig. 16). The connector can be stored in an adjacent space in the upper frame (fig. 17).
6. Put back the inner frame and the curtain frame without the mosquito roller.

Provided the wiring is done correctly, the installation will meet EMC standards 2004/108/EG and 2004/104/EG, annex 1: 6.5; 6.6; 6.8 and 6.9. The fan has approval KBA no. 19303 for installation on vehicles.

USE OF THE VENTILATOR

- The ventilator is started by the soft switch S2. The middle LED light lights up and the ventilator starts in comfort mode, this is the lowest speed (extract). See fig. 18.
- By pushing on the switch S1 (extraction) or S3 (intake), the airflow can be adjusted in 6 steps. See table 19.
 - * MIN = 3,7 m³/min. (2 W - 0,15 A)
 - * MAX = 20 m³/min. (34 W - 2,50 A)
- In order to save the battery, the speed drops from position 6 to the lowest position after one hour of use.
- It is possible to allow the ventilator to work for 5 minutes on the highest speed (boost). To do this push for 3 seconds on the button S1 (extract) or S3 (intake). After 5 minutes the ventilator returns to its previous speed setting. See table in fig. 20.
- For reasons of security, the ventilator stops when the tension is too high (19,5V) or too low (11,1V) or when the fan is blocked. For trouble shooting see fig. 21.

VENTILATOR WITH SUPPLEMENTARY SWITCH

- If an external thermostat or proximity switch (with time-delay relay with normal closed contact) is connected, you can turn the ventilator on or off with the switch S2 and choose the direction and speed with the switch S1 or S3. The ventilator will only work when the external thermostat or proximity switch is activated.
- Remark: If you will be away from the vehicle for a long period we suggest that you set the fan at a low speed level when using the thermostat. This will reduce the possibility of draining the battery.

MAINTENANCE

The ventilator grid can be removed for cleaning. Also the mosquito screens can be taken out for cleaning. Always shut down the current with the main switch.

REMARK ON THE TRANSPORT OF THE CARAVAN WITH THULE VENT

The roof light is only waterproof in the direction of the traffic. When transporting the caravan in the opposite direction, or when the back of the caravan is up, ensure the dome is watertight by using the 'Lock-unlock' (not supplied on a ventilator version) or by using something that ensures that the dome remains closed when being transported.

Thule Vent & Thule Vent 12V

DL921-09

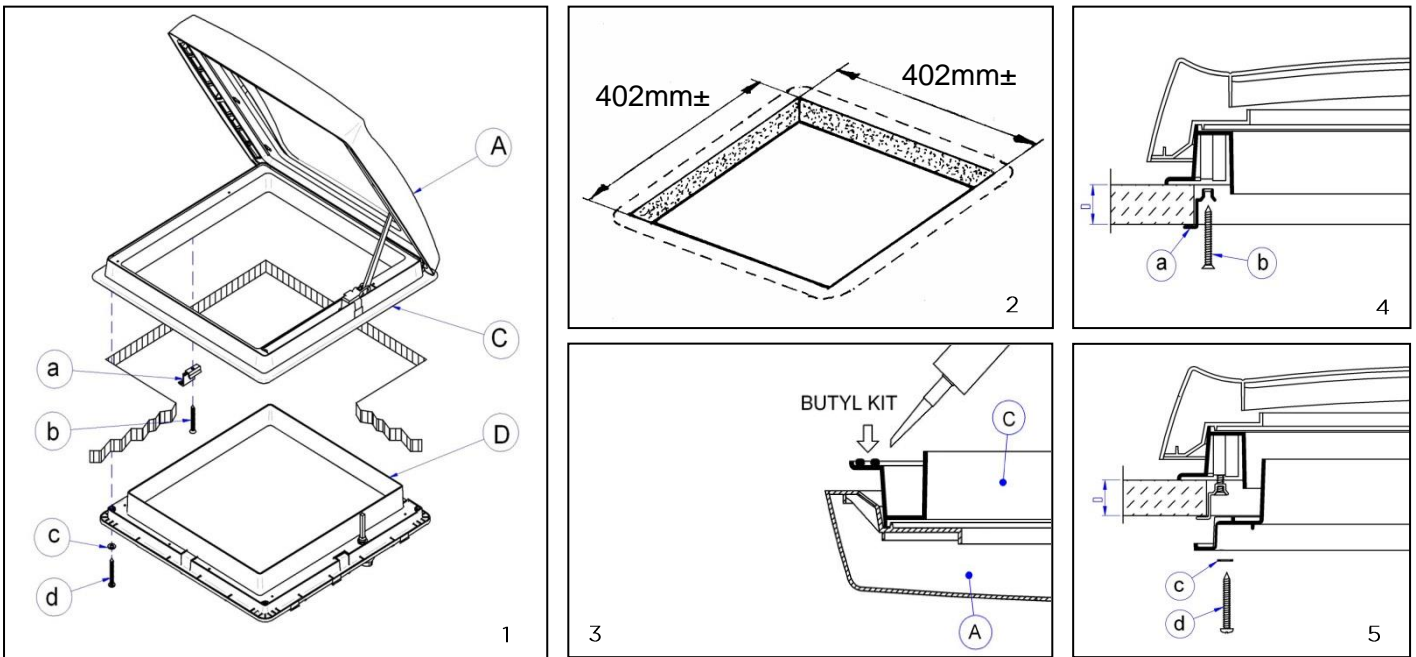

D	b DIN7982 4,2 x	d DIN7981 4,2 x
25-30	25	32
30-35	32	38
35-40	38	45
40-45	45	50
45-50	50	60
50-55	55	65
55-60	65	70

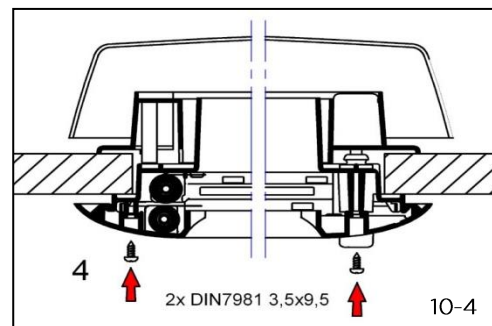
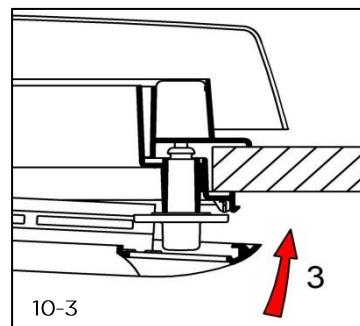
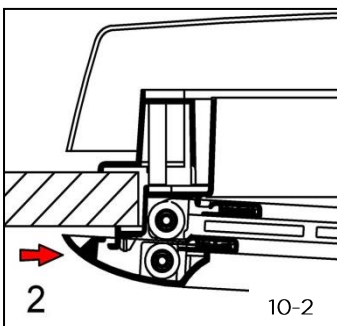
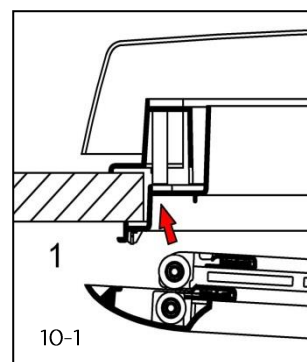
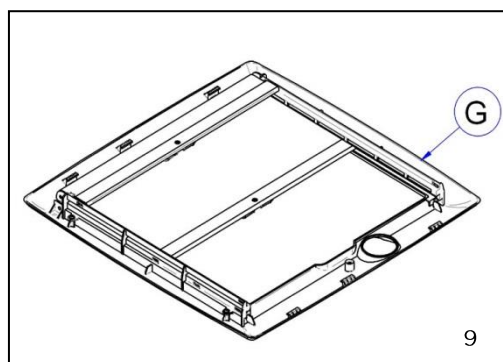
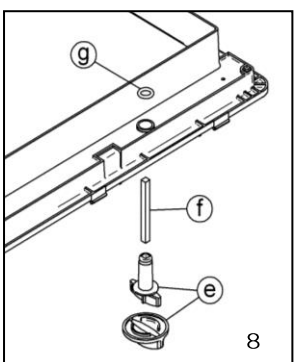
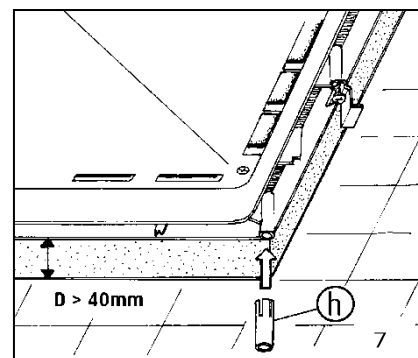
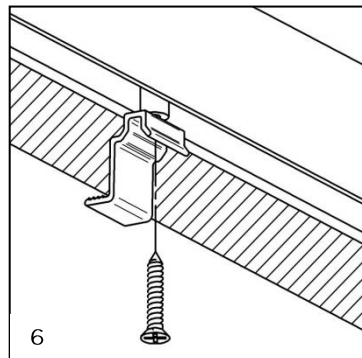

Thule Vent & Thule Vent 12V

DL921-09

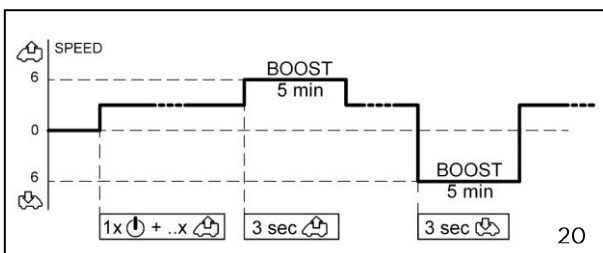
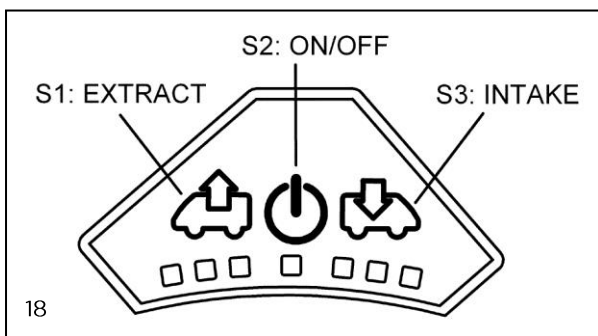
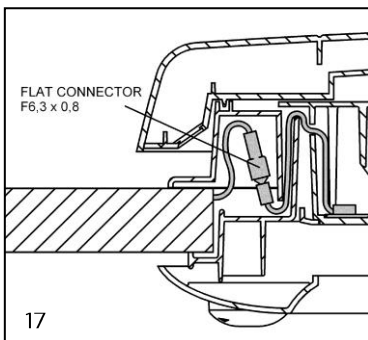
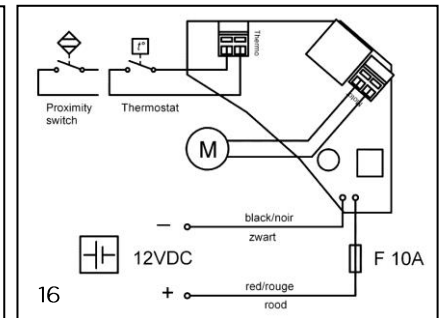
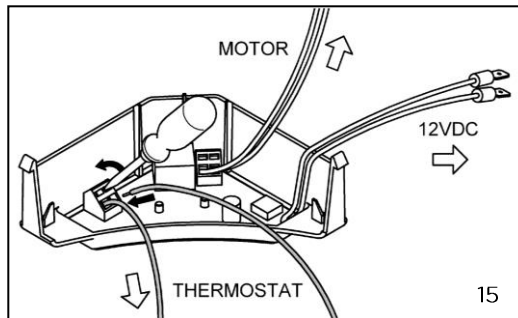
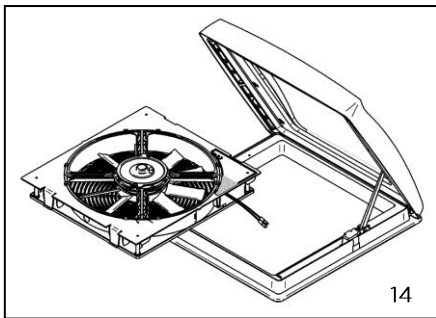
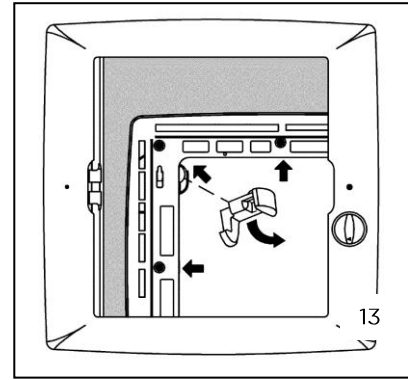
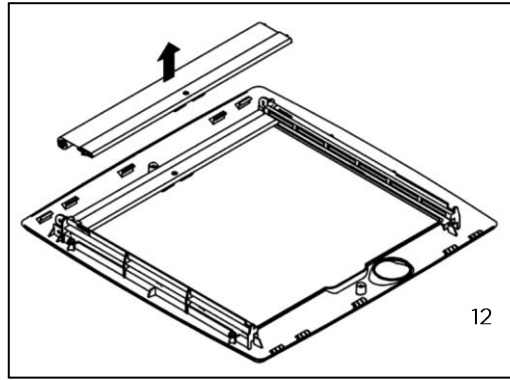
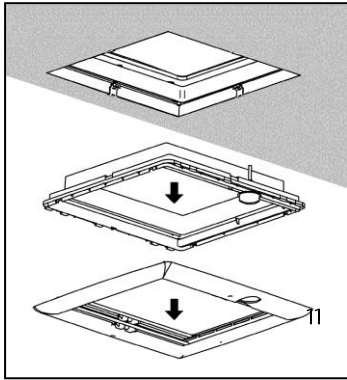

PUSH BUTTONS	LIGHTS	SPEED	Ampère	Watt
	■ ■ ■ ■ ■ ■ ■ ■	0	0,2 mA	2,4 mW
1x ⬆	■ ■ ■ ■ ■ ■ ■ ■	1⬆	0,15 A	2 W
1x ⬆ + 1x ⬇	■ ■ ■ ■ ■ ■ ■ ■	2⬆	0,35 A	5 W
1x ⬆ + 2x ⬇	■ ■ ■ ■ ■ ■ ■ ■	3⬆	0,65 A	9 W
1x ⬆ + 3x ⬇	■ ■ ■ ■ ■ ■ ■ ■	4⬆	1,20 A	17 W
1x ⬆ + 4x ⬇	■ ■ ■ ■ ■ ■ ■ ■	5⬆	1,70 A	24 W
1x ⬆ + 5x ⬇	■ ■ ■ ■ ■ ■ ■ ■	6⬆	2,50 A	34 W
1x ⬆ + 5x ⬇ + 1x ⬇	■ ■ ■ ■ ■ ■ ■ ■	5⬆		
1x ⬆ + 5x ⬇ + 2x ⬇	■ ■ ■ ■ ■ ■ ■ ■	4⬆		
... ..				
1x ⬆	■ ■ ■ ■ ■ ■ ■ ■	0	0,2 mA	2,4 mW

PUSH BUTTONS	LIGHTS	SPEED	Ampère	Watt
	■ ■ ■ ■ ■ ■ ■ ■	0	0,2 mA	2,4 mW
1x ⬆	■ ■ ■ ■ ■ ■ ■ ■	1⬆	0,15 A	2 W
1x ⬆ + 1x ⬇	■ ■ ■ ■ ■ ■ ■ ■	0	15 mA	0,2 W
1x ⬆ + 2x ⬇	■ ■ ■ ■ ■ ■ ■ ■	1⬇	0,15 A	2 W
1x ⬆ + 3x ⬇	■ ■ ■ ■ ■ ■ ■ ■	2⬇	0,30 A	5 W
1x ⬆ + 4x ⬇	■ ■ ■ ■ ■ ■ ■ ■	3⬇	0,50 A	9 W
... ..				

TROUBLE SHOOTING

FLASHING LED's	PROBLEM
■ ■ ■ ■ ■ ■ ■ ■	or Tension < 11,1 V or Tension > 19,5V
■ ■ ■ ■ ■ ■ ■ ■	Motor blocked
■ ■ ■ ■ ■ ■ ■ ■	Motor not connected